



INTERNATIONAL APPLICATION PUBLISHED UNDER THE PATENT COOPERATION TREATY (PCT)

(51) International Patent Classification: A61B 17/08	A1	(11) International Publication Number: WO 00/27292 (43) International Publication Date: 18 May 2000 (18.05.2000)
(21) International Application Number: PCT/US99/26325 (22) International Filing Date: 08 November 1999 (08.11.1999) (30) Priority Data: 09/187,200 06 November 1998 (06.11.1998) US (60) Parent Application or Grant MV MEDICAL DEVICES, INC. [/]; O. VAN DER BURG, Erik [/]; O. LESH, Michael, D. [/]; O. DE CICCIO, Dino [/]; O. FRAZIER, Andrew, G., C. [/]; O. KHAIRKAHAN, Alex, K. [/]; O. KREIDLER, Marc, S. [/]; O. ROUCE, Chad, C. [/]; O. SIMPSON, Andrew, H. ; O.	Published	
(54) Title: METHOD AND DEVICE FOR LEFT ATRIAL APPENDAGE OCCLUSION (54) Titre: PROCEDE ET DISPOSITIF POUR OCCLUSION DE L'AURICULE CARDIAQUE GAUCHE		
(57) Abstract <p>This invention is an occlusion device (10) for use in a body lumen such as the left atrial appendage (31). The occlusion device includes an occlusion member (11), and may also include a stabilizing member (12). The stabilizing member inhibits compression of the left atrial appendage, facilitating tissue ingrowth onto the occlusion member. The method of making the device includes forming a plurality of slots in a tube, the slots creating radially outwardly biased longitudinal elements (228). A membrane barrier (15) is then attached to the elements.</p> (57) Abrégé <p>L'invention concerne un dispositif d'occlusion (10) destiné à une cavité corporelle telle que l'auricule cardiaque gauche (31). Ce dispositif d'occlusion comporte un élément d'occlusion (11) et peut également comporter un élément de stabilisation (12). Cet élément de stabilisation (12) inhibe la compression de l'auricule cardiaque gauche, facilitant ainsi l'interposition de tissu sur l'élément d'occlusion. Le procédé de fabrication de ce dispositif consiste à pratiquer sur un tube une pluralité de fentes, ce qui a pour effet de créer des éléments longitudinaux (228) orientés dans le sens radial vers l'extérieur. On fixe ensuite une barrière membranaire (15) à ces éléments.</p>		

PCT

WORLD INTELLECTUAL PROPERTY ORGANIZATION
International Bureau



INTERNATIONAL APPLICATION PUBLISHED UNDER THE PATENT COOPERATION TREATY (PCT)

(51) International Patent Classification ⁶ : A61B 17/08	A1	(11) International Publication Number: WO 00/27292
		(43) International Publication Date: 18 May 2000 (18.05.00)

(21) International Application Number: PCT/US99/26325
(22) International Filing Date: 8 November 1999 (08.11.99)
(30) Priority Data:
09/187,200 6 November 1998 (06.11.98) US
(71) Applicant: MV MEDICAL DEVICES, INC. [US/US]; 530 Logue Avenue, Mountain View, CA 94043 (US).
(72) Inventors: VAN DER BURG, Erik; 587 Dawn Drive, Sunnyvale, CA 94087 (US). LESH, Michael, D.; 301 Monte Vista Avenue, Mill Valley, CA 94941 (US). DE CICCO, Dino; 497 La Conner Drive, Sunnyvale, CA 94087 (US). FRAZIER, Andrew, G., C.; 355 N. Wolfe Road, Apt. #218, Sunnyvale, CA 94086 (US). KHAIRKAHAN, Alex, K.; 1105 Lincoln Avenue, Palo Alto, CA 94301 (US). KREIDLER, Marc, S.; 645 E. McKinley Avenue, Sunnyvale, CA 94086 (US). ROUCE, Chad, C.; 845 Posada Drive, Sunnyvale, CA 94087 (US).
(74) Agent: SIMPSON, Andrew, H.; Knobbe, Martens, Olson and Bear, LLP, 16th Floor, 620 Newport Center Drive, Newport Beach, CA 92660 (US).

(81) Designated States: AE, AL, AM, AT, AU, AZ, BA, BB, BG, BR, BY, CA, CH, CN, CR, CU, CZ, CZ (Utility model), DE, DE (Utility model), DK, DK (Utility model), DM, EE, EE (Utility model), ES, FI, FI (Utility model), GB, GD, GE, GH, GM, HR, HU, ID, IL, IN, IS, JP, KE, KG, KP, KR, KZ, LC, LK, LR, LS, LT, LU, LV, MA, MD, MG, MK, MN, MW, MX, NO, NZ, PL, PT, RO, RU, SD, SE, SG, SI, SK, SK (Utility model), SL, TJ, TM, TR, TT, TZ, UA, UG, UZ, VN, YU, ZA, ZW, ARIPO patent (GH, GM, KE, LS, MW, SD, SL, SZ, TZ, UG, ZW), Eurasian patent (AM, AZ, BY, KG, KZ, MD, RU, TJ, TM), European patent (AT, BE, CH, CY, DE, DK, ES, FI, FR, GB, GR, IE, IT, LU, MC, NL, PT, SE), OAPI patent (BF, BJ, CF, CG, CI, CM, GA, GN, GW, ML, MR, NE, SN, TD, TG).

Published
With international search report.

(54) Title: METHOD AND DEVICE FOR LEFT ATRIAL APPENDAGE OCCLUSION

(57) Abstract

This invention is an occlusion device (10) for use in a body lumen such as the left atrial appendage (31). The occlusion device includes an occlusion member (11), and may also include a stabilizing member (12). The stabilizing member inhibits compression of the left atrial appendage, facilitating tissue ingrowth onto the occlusion member. The method of making the device includes forming a plurality of slots in a tube, the slots creating radially outwardly biased longitudinal elements (228). A membrane barrier (15) is then attached to the elements.

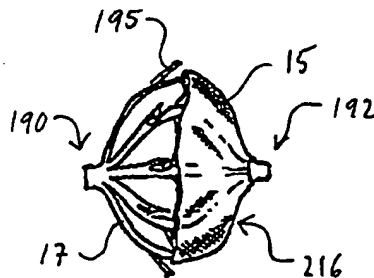

FOR THE PURPOSES OF INFORMATION ONLY

Codes used to identify States party to the PCT on the front pages of pamphlets publishing international applications under the PCT.

AL	Albania	ES	Spain	LS	Lesotho	SI	Slovenia
AM	Armenia	FI	Finland	LT	Lithuania	SK	Slovakia
AT	Austria	FR	France	LU	Luxembourg	SN	Senegal
AU	Australia	GA	Gabon	LV	Latvia	SZ	Swaziland
AZ	Azerbaijan	GB	United Kingdom	MC	Monaco	TD	Chad
BA	Bosnia and Herzegovina	GE	Georgia	MD	Republic of Moldova	TG	Togo
BB	Barbados	GH	Ghana	MG	Madagascar	TJ	Tajikistan
BE	Belgium	GN	Guinea	MK	The former Yugoslav Republic of Macedonia	TM	Turkmenistan
BF	Burkina Faso	GR	Greece	ML	Mali	TR	Turkey
BG	Bulgaria	HU	Hungary	MN	Mongolia	TT	Trinidad and Tobago
BJ	Benin	IE	Ireland	MR	Mauritania	UA	Ukraine
BR	Brazil	IL	Israel	MW	Malawi	UG	Uganda
BY	Belarus	IS	Iceland	MX	Mexico	US	United States of America
CA	Canada	IT	Italy	NE	Niger	UZ	Uzbekistan
CF	Central African Republic	JP	Japan	NL	Netherlands	VN	Viet Nam
CG	Congo	KE	Kenya	NO	Norway	YU	Yugoslavia
CH	Switzerland	KG	Kyrgyzstan	NZ	New Zealand	ZW	Zimbabwe
CI	Côte d'Ivoire	KP	Democratic People's Republic of Korea	PL	Poland		
CM	Cameroon	KR	Republic of Korea	PT	Portugal		
CN	China	KZ	Kazakistan	RO	Romania		
CU	Cuba	LC	Saint Lucia	RU	Russian Federation		
CZ	Czech Republic	LI	Liechtenstein	SD	Sudan		
DE	Germany	LK	Sri Lanka	SE	Sweden		
DK	Denmark	LR	Liberia	SG	Singapore		
EE	Estonia						

Description

5

10

15

20

25

30

35

40

45

50

55

5

METHOD AND DEVICE FOR LEFT ATRIAL APPENDAGE OCCLUSION

Background of the Invention

10

5

Embolic stroke is the nation's third leading killer for adults, and is a major cause of disability. There are over 700,000 strokes per year in the United States alone. Of these, roughly 100,000 are hemorrhagic, and 600,000 are ischemic (either due to vessel narrowing or to embolism). The most common cause of embolic stroke emanating from the heart is thrombus formation due to atrial fibrillation. Approximately 80,000 strokes per year are attributable to atrial fibrillation. Atrial fibrillation is an arrhythmia of the heart that results in a rapid and chaotic heartbeat that produces lower cardiac output and irregular and turbulent blood flow in the vascular system. There are over five million people worldwide with atrial fibrillation, with about four hundred thousand new cases reported each year. Atrial fibrillation is associated with a 500 percent greater risk of stroke due to the condition. A patient with atrial fibrillation typically has a significantly decreased quality of life due, in part, to the fear of a stroke, and the pharmaceutical regimen necessary to reduce that risk.

15

10

20

For patients who develop atrial thrombus from atrial fibrillation, the clot normally occurs in the left atrial appendage (LAA) of the heart. The LAA is a cavity which looks like a small finger or windsock and which is connected to the lateral wall of the left atrium between the mitral valve and the root of the left pulmonary vein. The LAA normally contracts with the rest of the left atrium during a normal heart cycle, thus keeping blood from becoming stagnant therein, but often fails to contract with any vigor in patients experiencing atrial fibrillation due to the discoordinate electrical signals associated with AF. As a result, thrombus formation is predisposed to form in the stagnant blood within the LAA.

25

15

30

20

Blackshear and Odell have reported that of the 1288 patients with non-rheumatic atrial fibrillation involved in their study, 221 (17%) had thrombus detected in the left atrium of the heart. Blackshear JL, Odell JA., Appendage Obliteration to Reduce Stroke in Cardiac Surgical Patients With Atrial Fibrillation. Ann Thorac. Surg., 1996.61(2):755-9. Of the patients with atrial thrombus, 201 (91%) had the atrial thrombus located within the left atrial appendage. The foregoing suggests that the elimination or containment of thrombus formed within the LAA of patients with atrial fibrillation would significantly reduce the incidence of stroke in those patients.

35

25

40

Pharmacological therapies for stroke prevention such as oral or systemic administration of warfarin or the like have been inadequate due to serious side effects of the medications and lack of patient compliance in taking the medication. Invasive surgical or thorascopic techniques have been used to obliterate the LAA, however, many patients are not suitable candidates for such surgical procedures due to a compromised condition or having previously undergone cardiac surgery. In addition, the perceived risks of even a thorascopic surgical procedure often outweigh the potential benefits. See Blackshear and Odell, above. See also Lindsay BD., Obliteration of the Left Atrial Appendage: A Concept Worth Testing, Ann Thorac. Surg., 1996.61(2):515.

45

30

50

Despite the various efforts in the prior art, there remains a need for a minimally invasive method and associated devices for reducing the risk of thrombus formation in the left atrial appendage.

55

5

Summary of the Invention

10

5

There is provided in accordance with one aspect of the present invention, a method of occluding an atrial appendage. The method comprises the steps of inhibiting changes in the volume of the appendage, and occluding the opening to the appendage. The inhibiting changes in the volume step preferably comprises introducing a bulking element into the appendage to resist compression of the appendage wall. Preferably, the bulking element is an expandable element. In one embodiment, the introducing an expandable bulking element step comprises deploying a self-expandable bulking element from a deployment catheter. The occluding step comprises positioning an occlusion element to enclose the bulking element within the appendage.

15

10

In accordance with another aspect of the present invention, there is provided a method of facilitating cell growth onto an atrial appendage occlusion device. The method comprises the steps of positioning an occlusion device across the opening of the appendage, the occlusion device having a tissue attachment surface thereon. The method additionally comprises the step of resisting compression of the appendage at least during a tissue attachment period of time. The resisting step preferably comprises positioning a bulking structure within the appendage.

20

25

15

In accordance with a further aspect of the present invention, there is provided an occlusion device for implantation within the left atrial appendage. The occlusion device comprises an occluding member, enlargeable from a reduced cross section to an enlarged cross section. The occlusion device may further comprise a stabilizing member, enlargeable from a reduced cross section to an enlarged cross section. The enlarged cross section of the stabilizing member may be less than the enlarged cross section of the occlusion member. Any of the occluding member and stabilizing member structures disclosed herein can be provided as an occluding member alone, without the corresponding stabilizing member.

30

20

35

25

The occlusion device preferably further comprises a hub between the occlusion member and the stabilizing member. The occlusion member comprises an expandable frame, which may be made from at least two spokes. Each spoke has a first end and a second end, and the first end is attached to the hub. The spokes are movable between an axial orientation to provide a low profile such as for transluminal implantation, and a radially enlarged orientation such as during implantation within the appendage to occlude the appendage.

40

30

The stabilizing member comprises at least two elements which are movable from an axial orientation when the stabilizing member is in the reduced cross section to an inclined orientation when the stabilizing member is in the enlarged cross section. In one embodiment, each element comprises a proximal section, a distal section, and a bend in-between the proximal and distal sections when the stabilizing member is in the enlarged cross section. Preferably, the occlusion device further comprises at least one tissue attachment element such as a hook, spike or barb.

45

50

35

In accordance with a further aspect of the present invention, there is provided an occlusion device for occluding a tubular body structure. The occlusion device comprises a body, having a longitudinal axis. An expandable occlusion member is provided at a first position on the axis, and a stabilizing member is provided at a second position on the axis. The occlusion member comprises a plurality of spokes which are hingeably attached to the body and movable between an axial orientation and an inclined orientation.

55

5 Preferably, the occlusion member further comprises a polymeric membrane carried by the spokes. The stabilizing member comprises at least three radially outwardly movable elements. In one embodiment, a hinge is provided on the body between the occlusion member and the stabilizing member. One hinge construction comprises a helical coil.

10 5 In accordance with a further aspect of the present invention, there is provided a method of making an occlusion device. The method comprises the steps of providing a tube, having a first end, a second end, and a longitudinal axis. A plurality of axially extending slots are cut at a first position on the tube, to create a first plurality of longitudinal elements. A second plurality of axially extending slots are cut at a second position on the tube, to create a second plurality of longitudinal elements.

15 10 The method further comprises the steps of providing a radially outwardly directed bias on at least one of the first and second plurality of elements. A polymeric membrane may be attached to at least one of the first and second plurality of elements. In one embodiment, a hinge is provided on the tube in-between the first and second plurality of elements.

20 15 In accordance with a further aspect of the present invention, there is provided a method of occluding an atrial appendage. The method comprises the steps of introducing a stabilizing member into the appendage, for resisting compression of the appendage wall, and preventing rotation and axial migration of the implant, and positioning an occlusion member across the appendage. The introducing step preferably comprises introducing a radially expandable stabilizing member, and radially expanding the member within the appendage. The positioning step may comprise either positioning the occlusion member within the appendage, or positioning the occlusion member across an opening of the appendage. In one embodiment, the introducing and positioning steps are accomplished by introducing a deployment catheter within the appendage and deploying the stabilizing member and occluding member from the catheter. Preferably, the method further comprises the step of facilitating cell growth onto the occlusion member.

25 30 Further features and advantages of the present invention will become apparent to those of ordinary skill in the art in view of the detailed description of preferred embodiments which follows, when considered together with the attached drawings and claims.

Brief Description of the Drawings

40 FIG. 1 shows a perspective view of an embodiment having features of the invention with an occluding member and a retention member.

FIG. 2 shows an end view of the apparatus of FIG. 1 in partial section.

30 45 FIG. 3 shows a longitudinal cross-sectional view of the apparatus of FIGS. 1 and 2.

FIG. 3A shows a perspective view of an apparatus having features of the invention.

FIG. 3B shows an elevational view in partial section of the apparatus of FIG. 3A.

50 FIG. 4 shows an elevational view of an apparatus having features of the invention in a deployed state within a body cavity.

- 5 FIG. 5 shows an elevational view of an apparatus having features of the invention in a deployed state within a body cavity.
- 10 FIG. 6 shows a perspective view of an apparatus for sealing off a body cavity having features of the invention.
- 5 FIG. 7 shows an elevational view in partial section of an apparatus for sealing off a body cavity having features of the invention.
- 15 FIG. 8 shows a transverse cross-sectional view of the apparatus of FIG. 7 taken along lines 8-8.
- FIG. 9 shows a schematic view of a patient's heart with a transeptal catheter deployed through the septum and a delivery catheter and apparatus for sealing off a body cavity disposed therein.
- 10 FIG. 10 shows a schematic view of a patient's heart in partial section with a delivery catheter disposed within the opening of the LAA.
- 20 FIG. 11 shows a magnified view of the delivery catheter distal end and the LAA of a patient of FIG. 10 with an apparatus for sealing off a body cavity partially deployed within the LAA.
- FIG. 12 shows the apparatus for sealing off a body cavity of FIG. 11 fully deployed within a LAA.
- 15 FIG. 13 shows an elevational view of a device for occluding a body cavity having features of the invention.
- 25 FIG. 14 shows a transverse cross sectional view of the device for occluding a body cavity of FIG. 13 taken along lines 14-14.
- FIG. 15 shows a device for occluding a body cavity having features of the invention deployed within a LAA.
- 30 FIG. 16 shows a device for occluding a body cavity having features of the invention deployed within a LAA.
- 20 FIG. 17 shows a LAA being occluded by a method having features of the invention.
- FIG. 18 shows a LAA occluded by method having features of the invention.
- FIG. 19 shows a LAA occluded by method having features of the invention.
- 35 FIG. 20 is an elevational view of an apparatus for closing an interior body cavity of a patient in partial section having features of the invention.
- 25 FIG. 21 is a schematic view of an apparatus for closing an interior body cavity of a patient in contact with tissue of a LAA.
- 40 FIG. 22 is a schematic view of an apparatus for closing an interior body cavity of a patient in contact with tissue of a LAA.
- FIG. 23 shows a LAA which has been closed by a method having features of the invention.
- 30 FIG. 24 is a perspective view of an occlusion device in accordance with the present invention.
- 45 FIG. 25 is a side elevational view of the occlusion device shown in FIG. 24.
- FIG. 26 is a perspective view of an alternate embodiment of the present invention.
- FIG. 27 is a side elevational view of the embodiment shown in FIG. 26.
- FIG. 28 is a perspective view of a further embodiment of the present invention.
- 50 35 FIG. 29 is a side elevational view of the embodiment of FIG. 28.

5

FIG. 30 is a perspective view of a further occlusion device in accordance with the present invention. FIG. 30(A) is a side view of the device shown in FIG. 30.

FIG. 31 is an end view taken along the line 31-31 of FIG. 30.

FIG. 32 is a schematic illustration of an inflatable balloon positioned within the occlusion device of FIG. 30.

10

FIG. 33 is a schematic view of a pull string deployment embodiment of the occlusion device of FIG. 30.

5

FIGS. 34A and 34B are side elevational schematic representations of partial and complete barrier layers on the occlusion device of FIG. 30.

15

FIG. 35 is a side elevational schematic view of an alternate occlusion device in accordance with the present invention.

10

FIG. 36 is a schematic view of a bonding layer mesh for use in forming a composite barrier membrane in accordance with the present invention.

20

FIG. 37 is an exploded cross sectional view of the components of a composite barrier member in accordance with the present invention.

FIG. 38 is a cross sectional view through a composite barrier formed from the components illustrated in FIG. 37.

15

FIG. 39 is a top plan view of the composite barrier illustrated in FIG. 38.

25

Detailed Description of the Preferred Embodiment

30

20

FIGS. 1-3 show an embodiment of an occluding device 10 having features of the invention where an occluding member 11 is secured to a retention member 12 that is arranged to fix the occluding member in a desired position within a body passageway or cavity. The occluding member 11 generally has disc shape with an outer rim 13 around the perimeter of a frame structure 14 which supports a barrier 15. The outer rim 13 can be circular or polygonal, or any other shape that is suitable for conforming to the inside surface of a body cavity. A hub 16 can be located near the center of the occluding member 11 which serves to connect the retention member 12 to the occluding member, in addition to other functions. The outer rim 13 is typically made from a soft polymer material 17 which permits flexibility of the outer rim and facilitates sealing of the outer rim against the inside surface of a body cavity or passageway. The barrier 15 can be a thin mesh or film of material which serves to block the passage of material within an area surrounded by the outer rim 13. The barrier 15 can be secured to the outer rim 13 along its entire perimeter 18 in order to achieve a complete seal therebetween and can be molded into the outer rim 13 or bonded thereto by a suitable method such as gluing, welding, sewing or other suitable method.

35

25

40

The outer rim 13 is at least partially supported by the frame structure 14 which connects the outer rim and the hub. The frame structure 14 can be made from one or more elements of high strength material such as stainless steel or MP35N, or may preferably be made from shape memory or pseudoelastic alloys such as NiTi, or any of a variety of known structural biodegradable materials (e.g. polyglycolic acid, poly lactic acid, poly-L-lactic acid and derivatives or copolymers such as PLGA). Preferably, the frame structure 14 is made from a material which can be self-expanding from a constrained configuration so that the occluding device 10 can be delivered to the deployment site in a low profile and flexible configuration which facilitates percutaneous delivery.

45

35

50

55

5 Preferably a radial hoop 21 is contained within the soft polymer material 17 of the outer rim 13 and serves to maintain the annular shape of the outer rim and facilitate radial expansion of the outer rim from a constrained position or configuration. The radial hoop 21 may be isolated within the soft polymer material 17 of the outer rim 13, or may be connected to at least some of the elements 22 of the frame structure 14, in order to have stronger
10 5 mechanical joint between the outer rim and the frame structure. The radial hoop 21 is shown in a substantially circular configuration, but may also be polygonal or otherwise suitably shared, and may have connections or joints spaced thereon to facilitate contraction or folding of the device for non-invasive delivery.

15 In addition to connecting the retention member 12 and the occluding member 11, the hub 16 may serve to house a rotational coupling 23 which is connected to the proximal end 24 of a tissue penetrating shaft 25 within the retention member. The rotational coupling 23 allows the transfer of torque to the tissue penetrating shaft 25 which preferably has a helically shaped extension or distal extremity 26 which is configured to screw into tissue and be
20 mechanically fixed thereto. Longitudinal movement of the tissue penetrating shaft 25 relative to the retention member 12 and hub 16 may be prevented by sizing a lumen 27 of the retention member which contains the tissue penetrating shaft such that the helically shaped extension 26 at the distal end is too large to pass through the lumen and the proximal end 24 of the tissue penetrating shaft is prevented from passing through the lumen by the rotational coupling attached thereto. The rotational coupling 23 may also be configured to be longitudinally captured by the hub 16 but still be rotatably disposed therein.

30 FIGS. 3A and 3B depict an alternative embodiment of an occluding device 10 having an occluding member 11 and a retention member 12. The retention member 12 has a shaft 28 and radially extending members 29 extending radially from a proximal end of the shaft. The radially extending members 29 serve to anchor the shaft 28 and the occluding member 11 by engaging the tissue surrounding the occluding device. Preferably, the radially extending members are self-expanding from a constricted state and are made of a pseudo elastic alloy such as NiTi, or a high
35 strength material such as stainless steel. Although it is preferable for the radially extending members 29 to be self-expanding from a constricted state, they may also be expanded by use of shape memory properties or a radial outward force as would be provided by an inflatable balloon or the like. The shaft 28 can be a single element or made of multiple elements, and can be made from the same materials as the radially extending members or different materials
40 such as polymers or polymer composites. The radially extending members 29 have a proximally directed bias at their radial extremities 29A so that the members readily fold down and move easily in a distal direction during insertion of the occluding device 10, but spring outward and aggressively engage surrounding tissue upon movement in a proximal direction. This configuration of the radially extending members 29 allows easy insertion into a body cavity, but prevents egress of the device 10 in and outward or proximal direction.

45 FIG. 4 depicts an occluding device 30 similar to that depicted in FIGS. 1-3 deployed within the left atrial appendage 31 of a patient. An outer rim or periphery 32 of the occluding device 30 is disposed adjacent the opening 33 of the left atrial appendage 31 in a position which allows for a substantial seal of the outer rim against the inside
50 35 surface 34 of the LAA. A helically shaped distal extremity 35 of a tissue penetrating shaft 36 has been screwed into

5 the wall tissue of the LAA and is mechanically secured thereto. A retention member 38 maintains the position of an occluding member 41 in a substantially perpendicular orientation with respect to a longitudinal axis of the LAA 42.

10 5 FIG. 5 depicts an occluding device similar to that depicted in FIGS. 1-4 deployed within a LAA 51 of a patient similar to what is shown in FIG. 4. The structure of an occluding member 52 of the embodiment as shown in FIG. 5 differs from that shown in FIG. 4 in that a barrier 53 and frame structure 54 of the embodiment of FIG. 5 protrudes proximally from a plane defined by an outer rim 55. This configuration may be useful for certain morphologies of patient's LAAs. One object of the invention is to create a smooth surface outside the body passageway or cavity in order to prevent turbulent flow or eddies of blood or other bodily fluid within the cavity or passageway. The alternative configuration of the occluding device 50 shown in FIG. 5 may be useful in this regard.

15 10 FIG. 6 shows an alternative embodiment of an occluding device 60 which has an occluding member 61, a frame structure 62, a barrier 63 and a retention member in the form of an expandable member 65 which has linked elements 66 that are preferably expandable from a constrained configuration. The expandable member 65 is generally cylindrical in shape and can have a series of circumferential linked elements 66 connected by links 68. Although FIG. 6 depicts the expandable member 65 as a series of linked elements 66, those skilled in the art will realize that a similar effect can be achieved with a single wire in a helical configuration or a plurality of wires in a mesh or braided configuration, or any other suitable configuration that can be self-expanding from a constrained configuration or expanding with the application of heat or other form of energy or force. For example, the expandable member 65 may be configured to be deployed by an outward radial force delivered from within the expandable member. An inflatable balloon or the like could be used to exert such a force. The expandable member is preferably secured to an outer rim 71 of the occluding member 61 but may also be secured to the frame structure 62 directly or indirectly. The expandable member 65 can be self-expanding from a constrained configuration as can the occluding member 61 and the frame structure 62 and outer rim 71 thereof. The frame structure 62, outer rim 71 and barrier 63 may have construction similar to that described above with regard to the similar elements of the embodiments depicted in FIGS. 1-5.

25 20 Referring to FIG. 7, the expandable member 65 as shown in FIG. 6 may also have a sheath 72 disposed around it so as to act as a shield between the expandable member and an inner surface of a patient's body cavity or passageway. The sheath 72 may facilitate the sealing function of the occluding member 61, but is primarily intended to prevent damage to either tissue on the inside surface of a body cavity or to the linked elements 66 of the expandable member. The sheath 72 may surround all or part of the expandable member 65 and may be made from a variety of suitable biocompatible materials such as Dacron®, Nylon, TFE, PTFE or ePTFE. The sheath 72 may be a weave, braid, film or have any other suitable configuration. Expandable member 65 may also be coated by dipping, spraying, or other suitable process with a friction reducing material such as Teflon®, or with an active compound such as heparin.

30 35 FIG. 8 shows a transverse cross-sectional view of the embodiment of FIG. 7 taken at lines 8-8. The frame structure 62 has an axis or hub 73 disposed at approximately the center of the frame structure which serves to

5 connect the various radial elements 74 of the frame structure. The hub 73 can have an independent structure that
links the several elements 74 of the frame structure 62 or it may be merely the terminus of the various frame structure
elements and have a solid composition. In either structure, the hub 73 preferably allows a constrained configuration of
10 the occluding member 61 to facilitate percutaneous delivery of the occluding device 60. The hub 73 may also have a
5 lumen disposed therein to allow passage of a guidewire or other guiding member. Preferably, the lumen would have a
self sealing valve or gasket which prevents the passage of fluid or embolic material once the guidewire or guiding
member is removed from the lumen.

15 Referring to FIG. 9, a schematic view of a patient's heart 80 in partial section shows a trans-septal catheter
81 having a proximal end 82 and a distal end 83. The distal end 83 of the trans-septal catheter 81 is disposed within
10 a patient's heart 80 with the distal end 84 of a delivery catheter 85 extending from the distal end 83 of the trans-
septal catheter. The distal end 83 of the trans-septal catheter 81 has breached the septum 86 of the patient's heart
20 80 and is disposed adjacent the opening of the patient's LAA 88. At the proximal end 82 of the trans-septal catheter
81 there is a Luer connector 91 coupled to a hemostasis valve 92 which prevents the egress of blood from a lumen 93
of the trans-septal catheter 81. The proximal end 94 of the delivery catheter 85 extends proximally from the
15 hemostasis valve 92 and has a Luer connector 95 attached to the proximal extremity thereof. The proximal end 96 of
a plunger 97 extends from the Luer connector 95 of the delivery catheter. The proximal end 94 of the delivery
25 catheter is arranged to allow rotational and axial movement of the plunger 97 while preventing blood or other bodily
fluids from leaking between the delivery catheter 85 and the plunger 97.

30 Referring to FIG. 10, a patient's heart 80 is shown in partial section with the distal end 84 of a delivery
catheter 85 disposed within the LAA opening 87. FIG. 11 is a magnified view of the LAA 88 shown in FIG. 10 and the
20 distal end of the delivery catheter 84, which is shown in partial section, contains a plunger 97 which is slideably
disposed within an inner lumen 98 of the delivery catheter 85 and serves to apply axial force in a distal direction on the
collapsed occluding member 101 disposed within the delivery catheter so as to force the occluding device 102 from
35 the delivery catheter and deploy it. An occluding device 102 having an expandable member 103 and an occluding
member 101 secured thereto is partially deployed and extending from the distal end of the delivery catheter 84 into the
25 patient's LAA 88. The occluding device 102 can also be guided into the patient's LAA 88 by use of an appropriate
guidewire or guiding member.

40 FIG. 12 shows the occluding device 102 of FIG. 11 in a deployed state within the patient's LAA 88. An outer
rim 104 of the occluding member 101 is in substantial sealing contact with the inside surface 105 of the LAA 88. The
30 expandable member 103 has expanded so as to contact the inside surface 105 of the LAA and secure the occluding
device 102 thereto and maintain the occluding member 101 in a substantially perpendicular orientation relative to a
45 longitudinal axis 106 of the LAA 88. A barrier 107 is disposed within an area bounded by the outer rim 104 and is
positioned to prevent the passage of embolic or other material to or from the LAA 88. The distal end 108 of the
50 plunger 97 is extending from the distal end of the delivery catheter 84 after having pushed the occluding device 102
35 from the delivery catheter.

5 Referring to FIG. 13, an occluding device 110 having features of the invention is shown. The occluding
device 110 has a delivery catheter 111 with a distal end 112, a detachment mechanism 113 disposed on the distal end
of the delivery catheter and an occlusive body or inflatable member 114 detachably secured to the detachment
10 mechanism. The inflatable member 114 has a proximal end 115 and a distal end 116 with the proximal end being
attached to the detachment mechanism 113 and the distal end terminating at an end cap 117. The inflatable member
114 has an outside surface 118 that may contain a fibrosis inducing material such as Dacron® or other similar
materials. The inflatable member 114 may be made from a fluid tight film of polymer material which can be either
15 compliant or non-compliant. Preferably the inflatable member 114 is made from silicone, however, any suitable
material such as polyethylene, polyurethane or PET can be used.

20 The detachment mechanism 113 can be activated by mechanical force or by delivery of thermal or optical
energy by a suitable conduit. Alternatively, the inflatable member can be pushed into the LAA from the delivery
catheter 111 by an elongate push member without the use of a detachment mechanism. The inflatable member 114
can be filled with a gas, fluid or gel which is injected under pressure through the delivery catheter 114 and into the
inflatable member. Suitable fluids to inject would include saline and silicone. The inflatable member 114 may also be
15 filled with a polymer material that can be hardened. Autologous fluid such as blood, or collagen may also be used. A
fluid, gel or polymer used to fill the inflatable member may contain contrast agents such as gold, tantalum, bismuth,
barium sulfate or the like in order to improve visualization under fluoroscopy or x-ray imaging.

20 FIG. 14 is a transverse cross-sectional view of the occluding device 110 of FIG. 13 taken along lines 14-14.
An optional inner shaft 121 is shown disposed within the inflatable member 114, preferably in a concentric
arrangement. The inner shaft 121 provides longitudinal axial support to the inflatable member 114 so as to maintain a
longitudinal dimension of the inflatable member 114 when it is being inflated and deployed. The inner shaft 121 may
be solid or contain one or more lumens that may or may not be in fluid communication with an inner lumen 122 of the
35 inflatable member 114, and can be used for the passage of a guidewire or guiding member.

25 FIG. 15 depicts an alternative embodiment of an occluding device 110 which consists of an inflatable
member 114 similar to the inflatable member of FIG. 13, shown substantially deployed, within a patient's LAA 123.
The inflatable member 114 has been at least partially filled with a fluid, gas or gel within the patient's LAA 123 such
that the outside surface of the inflatable member 118 is in contact with at least part of the inside surface 124 of the
LAA. The inflatable member 114 can have rib members 125 which can mechanically interlock with the trabeculae 126
40 of the inside surface of the LAA 124 or other surface irregularities of the inside surface of a patient's body cavity or
passageway. The rib members 125 form a complete circumference of the inflatable member 114, but could also form
a partial circumference, spiral configuration, or consist of random projections on the surface of the inflatable member
118. The rib members 125 should extend radially about 1 to about 4 mm from the nominal surface of the inflatable
30 member 114, and are preferably spaced about 3 to about 8 mm from each other. The rib members 125 may be made
from any suitable polymer material, but are preferably made from the same material as the inflatable member, and are
integrally molded thereon, or bonded thereto with a heat weld or adhesive bond suitable for bonding flexibly medical
50 35

5 polymers. The inflatable member 114 is depicted with the distal end of the delivery catheter 112 and detachment
mechanism 113 attached. As an alternative, or in addition to the polymer rib members 125 shown in FIG. 15, barbs or
10 hooks could be secured to the outside surface of the inflatable member 114 which are configured to engage the inside
surface of a patient's LAA 124. Preferably, barbs or hooks disposed on the outside surface of the inflatable member
15 and configured to engage the tissue of the inside surface of a patient's LAA 124 would have a proximally directed bias
at their radial extremity so that the barbs would fold down and move easily in a distal direction during insertion of the
inflatable member 114, but would spring outward and aggressively engage the tissue of the body cavity upon
movement in a proximal direction of the inflatable member.

FIG. 16 depicts an occluding device 110 consisting of an inflatable member 114 which is shown deployed
10 within a patient's LAA 123. The embodiment of the inflatable member 114 shown in FIG. 16 has an optional retention
member 127 with a tissue penetrating shaft 128 which has a proximal 131 end and a distal end 132. A rotational
coupling 133 is disposed at the proximal end 131 of the tissue penetrating shaft 128 and a helically shaped extremity
20 134 is disposed at the distal end of the shaft 132. The helically shaped distal extremity 134 is shown deployed within
and mechanically engaging wall tissue 135 of the LAA so as to secure the inflatable member 114 and maintain its
15 position within the LAA 123 of the patient.

FIG. 17 shows an alternative embodiment of an occlusive member 140 consisting of a polymer mass 141
25 which has been injected or delivered into a patient's LAA 142. The distal end 143 of a delivery catheter 144 has a
lumen 145 therein which extends to a proximal end of the delivery catheter which is in fluid communication with a
source of pressurized polymer material. A source of pressurized polymer material 146 can be any type of pump or
30 device capable of forcing a polymer fluid or gel into the proximal end of the delivery catheter with sufficient pressure
to force the polymer fluid or gel out the distal end 143 of the delivery catheter 144 and into a patient's body cavity or
passageway. The delivery catheter 144 may be positioned by the techniques discussed above, e.g., the Mullins trans-
septal approach or any other suitable method. Once the distal end of the delivery catheter 143 is disposed within a
35 desired portion of the patient's LAA 142, the polymer mass 141 may be injected to fill the cavity to the desired level.
The LAA 142 can be completely or partially filled with the polymer mass 141 which can be formulated to harden over
25 time, with heat or remain in a fluid or gel state. The distal end of the delivery catheter can optionally include an
expandable member which is used to substantially seal the delivery catheter against the inside surface of the opening
40 of the patient's body cavity during the delivery of polymer material. The expandable member can be an inflatable
balloon or the like which are well known in the art.

30 Optionally, a retention member 127 having a tissue penetrating shaft 128 or the like, such as shown in FIG.
16 with regard to the inflatable member 114, may be deployed within the LAA 142 prior to injection of the polymer
45 mass 141 and captured thereby so as to secure the polymer mass within the LAA. Alternatively, the polymer mass
can be used to fill the patient's LAA and surround and secure a deployed device as shown in FIGS. 4 or 5 in the
50 patient's LAA 142.

5 Once a desired amount of polymer mass 141 has been injected into the LAA 142, as assessed for example by
TE Echo imaging, the delivery catheter 144 may be withdrawn and the procedure terminated. Preferably, the entire
LAA 142 of a patient is filled with the polymer mass 141 as shown in FIG. 18 and hardens or gels to maintain its
10 shape. It may be desirable to have the polymer mass 141 retain a soft compressible form after setting or hardening so
5 that it is at least partially compliant with the constrictive pumping action of a heart and resistant to fatigue as a result
thereof. A material used to form the polymer mass 141 may contain contrast agents such as gold, platinum, tantalum,
bismuth or the like in order to better visualize the deployment of the polymer mass under fluoroscopic or x-ray imaging.

15 Another alternative embodiment of an occlusive member 140 can be found in FIG. 19 which shows an
occlusive coil 147 which has been deployed within an LAA 142. The occlusive coil 147 as shown has assumed a
10 random configuration that is mechanically occluding the LAA 142 and which has induced clot and/or fibrosis formation
148 which further facilitates occlusion of the LAA 142.

20 An apparatus for closing off a body cavity or passageway 150 is shown in FIG. 20 which has features of the
present invention. The apparatus 150 has an elongate shaft 151 with an inner lumen 152 and a proximal end 153 and
a distal end 154. Slideably disposed within the inner lumen 152 of the elongate shaft 151 are at least two elongate
15 members 155 which have proximal ends 156 and distal ends 157 and have tissue attachment members 158 disposed
25 on the distal ends. An optional distal anchor member 161 is also slideably disposed within the inner lumen 152 of the
elongate shaft 151 and preferably has a distal end 162 terminating with a helical member 163. The proximal end 153
of the elongate shaft 151 has a proximal control module 164 which seals the inner lumen 152 of the elongate shaft
30 151 and allows rotation and translation of the proximal ends 156 of the elongate members 155 and the distal anchor
20 member 161 while maintaining a seal between said members to prevent leakage of bodily fluids therefrom. The
proximal control module 164 can optionally be configured to control advancement and retraction of the elongate
members 155 and control activation of the tissue attachment members 158.

35 FIG. 21 shows the apparatus for closing off a body cavity 150 of FIG. 20 with the distal ends of the elongate
members 157 and the tissue attachment members 158 extending distally from the distal end of the elongate shaft
25 154. The distal ends of the elongate members 157 are angled or deflected from a longitudinal axis 165 of the elongate
shaft 151 so as to engage tissue 166 of the opening 167 of the LAA 168 as shown. The elongate members 155 may
40 be deflected by an abutment or angulation contained in the distal end of the elongate shaft 154, but are preferably
preshaped in an angled configuration which manifests when the distal ends are freed of the constraint of the inner
lumen 152 of the elongate shaft and allowed to assume their relaxed preshaped condition. The helical member 163 at
30 the distal end 162 of the distal anchor member 161 is engaged with the wall tissue 171 of the LAA 168 so as to
45 provide an optional anchor that can be used to move the elongate shaft 151 relative to the distal anchor member 161
and give greater control of the longitudinal axial movement of the elongate shaft relative to the LAA opening 167. The
tissue attachment members 158 are shown attached to the annular edge 172 of the LAA opening 167. Once the
50 tissue attachment members 158 are attached, a closure member or retaining ring 173 may be advanced distally by
35 applying axial force on an elongate push shaft 174 which draws the tissue attachment members 158 and the tissue

5 attached thereto closer together as shown in FIG. 22. As the closure member 173 is further advanced distally, the
annular edge of the LAA 172 is drawn closed, and eventually, the annular edge of the LAA will be completely closed
10 into a closed state with the closure member 173 surrounding and compressing the tissue of the annular edge as shown
in FIG. 23. Once a closed state of the LAA is achieved, the tissue attachment members 158 may be detached, and the
5 apparatus for closing off a body cavity 150 withdrawn. One alternative method can have the tissue attachment
members 158 drawn together by retracting them proximally into the distal end 154 of the elongate shaft 151 as
opposed to distally advancing the closure member 173 with the elongate push shaft 174. In this way, the annular
15 edge of the LAA 172 can be drawn into a closed state within the distal end 154 of the elongate shaft 151 at which
point the annular edge may be fixed in the closed state by a variety of methods including suturing, tissue welding, the
10 application of a suitable biocompatible adhesive, surgical staples or the like.

Referring to FIGS. 24 and 25, there is illustrated an alternate embodiment of the occlusion device 10 in
20 accordance with the present invention. The occlusion device 10 comprises an occluding member 11 comprising a
frame 14 and a barrier 15. In the illustrated embodiment, the frame 14 comprises a plurality of radially outwardly
extending spokes 17 each having a length within the range of from about 0.5 cm to about 2 cm from a hub 16. In one
15 embodiment, the spokes have an axial length of about 1.5 cm. Depending upon the desired introduction crossing
profile of the collapsed occlusion device 10, as well as structural strength requirements in the deployed device,
anywhere within the range of from about 3 spokes to about 40 spokes may be utilized. In some embodiments,
25 anywhere from about 12 to about 24 spokes are utilized, and, 18 spokes are utilized in one embodiment.

The spokes are advanceable from a generally axially extending orientation such as to fit within a tubular
30 introduction catheter to a radially inclined orientation as illustrated in FIG. 24 and FIG. 25 following deployment from
the catheter. In a self-expandable embodiment, the spokes are biased radially outwardly such that the occlusion
member expands to its enlarged, implantation cross-section under its own bias following deployment from the catheter.
35 Alternatively, the occlusion member may be enlarged using any of a variety of enlargement structures such as an
inflatable balloon.

25 Preferably, the spokes comprise a metal such as stainless steel, Nitinol, Elgiloy, or others which can be
determined through routine experimentation by those of skill in the art. Wires having a circular or rectangular cross-
section may be utilized depending upon the manufacturing technique. In one embodiment, rectangular cross section
40 spokes are cut such as by known laser cutting techniques from tube stock, a portion of which forms the hub 16.

The barrier 15 may comprise any of a variety of materials which facilitate cellular in-growth, such as ePTFE.
30 The suitability of alternate materials for barrier 15 can be determined through routine experimentation by those of skill
in the art. The barrier 15 may be provided on either one or both sides of the occlusion member. In one embodiment,
45 the barrier 15 comprises two layers, with one layer on each side of the frame 14. The two layers may be bonded to
each other around the spokes 17 in any of a variety of ways, such as by heat bonding with or without an intermediate
50 bonding layer such as polyethylene or FEP, adhesives, sutures, and other techniques which will be apparent to those of

5 skill in the art in view of the disclosure herein. The barrier 15 preferably has a thickness of no more than about 0.003" and a porosity within the range of from about 5 μ m to about 60 μ m.

10 The barrier 15 in one embodiment preferably is securely attached to the frame 14 and retains a sufficient porosity to facilitate cellular ingrowth and/or attachment. One method of manufacturing a suitable composite
5 membrane barrier 15 is illustrated in Figures 36-39. As illustrated schematically in Figure 36, a bonding layer 254 preferably comprises a mesh or other porous structure having an open surface area within the range of from about 10% to about 90%. Preferably, the open surface area of the mesh is within the range of from about 30% to about 60%. The opening or pore size of the bonding layer 254 is preferably within the range of from about 0.005 inches to about 0.050 inches, and, in one embodiment, is about 0.020 inches. The thickness of the bonding layer 254 can be varied widely, and is generally within the range of from about 0.0005 inches to about 0.005 inches. In a preferred
10 embodiment, the bonding layer 254 has a thickness of about 0.001 to about 0.002 inches. One suitable polyethylene bonding mesh is available from Smith and Nephew, under the code SN9.

15 Referring to Figure 37, the bonding layer 254 is preferably placed adjacent one or both sides of a spoke or other frame element 14. The bonding layer 254 and frame 14 layers are then positioned in-between a first membrane 250 and a second membrane 252 to provide a composite membrane stack. The first membrane 250 and second 252 may comprise any of a variety of materials and thicknesses, depending upon the desired functional result. Generally, the membrane has a thickness within the range of from about 0.0005 inches to about 0.010 inches. In one embodiment, the membranes 250 and 252 each have a thickness on the order of from about 0.001 inches to about 0.002 inches, and comprise porous ePTFE, having a porosity within the range of from about 10 microns to about 100
20 microns.

25 The composite stack is heated to a temperature of from about 200° to about 300°, for about 1 minute to about 5 minutes under pressure to provide a finished composite membrane assembly with an embedded frame 14 as illustrated schematically in Figure 38. The final composite membrane has a thickness within the range of from about 0.001 inches to about 0.010 inches, and, preferably, is about 0.002 to about 0.003 inches in thickness. However, the thicknesses and process parameters of the foregoing may be varied considerably, depending upon the materials of the bonding layer 254 the first layer 250 and the second layer 252.

30 As illustrated in top plan view in Figure 39, the resulting finished composite membrane has a plurality of "unbonded" windows or areas 256 suitable for cellular attachment and/or ingrowth. The attachment areas 256 are bounded by the frame 14 struts, and the cross-hatch pattern formed by the bonding layer 254. In the illustrated embodiment, the filaments of the bonding layer 254 are oriented in a nonparallel relationship with the struts of frame 14, and, in particular, at an angle within the range of from about 15° to about 85° from the longitudinal axis of the struts. Preferably, a regular window 256 pattern is produced.

35 The foregoing procedure allows the bonding mesh to flow into the first and second membranes 250 and 252 and gives the composite membrane 15 greater strength (both tensile and tear strength) than the components without the bonding mesh. The composite allows uniform bonding while maintaining porosity of the membrane 15, to facilitate

5 tissue attachment. By flowing the thermoplastic bonding layer into the pores of the outer mesh layers 250 and 252, the composite flexibility is preserved and the overall composite layer thickness can be minimized.

10 The occlusion device 10 may be further provided with a bulking element or stabilizer 194. The stabilizer 194 may be spaced apart along an axis from the occluding member 11. In the illustrated embodiment, a distal end 190 and a proximal end 192 are identified for reference. The designation proximal or distal is not intended to indicate any particular anatomical orientation or deployment orientation within the deployment catheter. As shown in FIGS. 24 and 25, the stabilizer 194 is spaced distally apart from the occluding member 11.

15 For use in the LAA, the occluding member 11 has an expanded diameter within the range of from about 1 cm to about 5 cm, and, in one embodiment, about 3 cm. The axial length of the occluding member 11 in an expanded, unstressed orientation from the distal end 192 to the proximal hub 16 is on the order of about 1 cm. The overall length of the occlusion device 10 from the distal end 192 to the proximal end 190 is within the range of from about 1.5 cm to about 4 cm and, in one embodiment, about 2.5 cm. The axial length of the stabilizer 194 between distal hub 191 and proximal hub 16 is within the range of from about 0.5 cm to about 2 cm, and, in one embodiment, about 1 cm. The expanded diameter of the stabilizer 194 is within the range of from about 0.5 cm to about 2.5 cm, and, in one embodiment, about 1.4 cm. The outside diameter of the distal hub 191 and proximal hub 16 is about 2.5 mm.

20 Preferably, the occlusion device 10 is provided with one or more retention structures for retaining the device in the left atrial appendage or other body lumen. In the illustrated embodiment, a plurality of barbs or other anchors 195 are provided, for engaging adjacent tissue to retain the occlusion device 10 in its implanted position and to limit relative movement between the tissue and the occlusion device. The illustrated anchors are provided on one or more of the spokes 17, or other portion of frame 14. Preferably, every spoke, every second spoke or every third spoke are provided with one or two anchors each. The illustrated anchor is in the form of a barb, for extending into tissue at or near the opening of the LAA.

25 One or more anchors 195 may also be provided on the stabilizer 194, such that it assists not only in orienting the occlusion device 10 and resisting compression of the LAA, but also in retaining the occlusion device 10 within the LAA. Any of a wide variety of structures may be utilized for anchor 195, either on the occluding member 11 or the stabilizer 194 or both, such as hooks, barbs, pins, sutures, adhesives and others which will be apparent to those of skill in the art in view of the disclosure herein.

30 In use, the occlusion device 10 is preferably positioned within a tubular anatomical structure to be occluded such as the left atrial appendage such that the occluding member 11 is positioned across or near the opening to the LAA and the stabilizer 194 is positioned within the LAA. The stabilizer 194 assists in the proper location and orientation of the occluding member 11, as well as resists compression of the LAA behind the occluding member 11. The present inventors have determined that following deployment of an occluding member 11 without a stabilizer 194 or other bulking structure to resist compression of the LAA, normal operation of the heart may cause compression and resulting volume changes in the LAA, thereby forcing fluid past the occluding member 11 and inhibiting or preventing a

5 complete seal. Provision of a stabilizer 194 dimensioned to prevent the collapse or pumping of the LAA thus minimize leakage, and provision of the barbs facilitates endothelialization or other cell growth across the occluding member 11:

10 5 For this purpose, the stabilizer 194 is preferably movable between a reduced cross-sectional profile for transluminal advancement into the left atrial appendage, and an enlarged cross-sectional orientation as illustrated to fill or to substantially fill a cross-section through the LAA. The stabilizing member may enlarge to a greater cross section than the anatomical cavity, to ensure a tight fit and minimize the likelihood of compression. One convenient construction includes a plurality of elements 196 which are radially outwardly expandable in response to axial compression of a distal hub 191 towards a proximal hub 16. Elements 196 each comprise a distal segment 198 and a proximal segment 202 connected by a bend 200. The elements 196 may be provided with a bias in the direction of the radially enlarged orientation as illustrated in FIG. 25, or may be radially expanded by applying an expansion force such as an axially compressive force between distal hub 191 and proximal hub 16 or a radial expansion force such as might be applied by an inflatable balloon. Elements 196 may conveniently be formed by laser cutting the same tube stock as utilized to construct the distal hub 191, proximal hub 16 and frame 14, as will be apparent to those of skill in the art in view of the disclosure herein. Alternatively, the various components of the occlusion device 10 may be separately fabricated or fabricated in subassemblies and secured together during manufacturing.

15 20 25 As a post implantation step for any of the occlusion devices disclosed herein, a radiopaque dye or other visualizable media may be introduced on one side or the other of the occlusion device, to permit visualization of any escaped blood or other fluid past the occlusion device. For example, in the context of a left atrial appendage application, the occlusion device may be provided with a capillary tube or aperture which permit introduction of a visualizable dye from the deployment catheter through the occlusion device and into the entrapped space on the distal side of the occlusion device. Alternatively, dye may be introduced into the entrapped space distal to the occlusion device such as by advancing a small gauge needle from the deployment catheter through the barrier 15 on the occlusion device, to introduce dye.

30 35 40 45 50 55 A further embodiment of the occlusion device 10 is illustrated in Figures 26-27. The occlusion device 10 comprises an occlusion member 11 and a stabilizing member 194 as in the previous embodiment. In the present embodiment, however, each of the distal segments 198 inclines radially outwardly in the proximal direction and terminates in a proximal end 204. The proximal end 204 may be provided with atraumatic configuration, for pressing against, but not penetrating, the wall of the left atrial appendage or other tubular body structure. Three or more distal segments 198 are preferably provided, and generally anywhere within the range of from about 6 to about 20 distal segments 198 may be used. In one embodiment, 9 distal segments 198 are provided. In this embodiment, 3 of the distal segments 198 have an axial length of about 5 mm, and 6 of the distal segments 198 have an axial length of about 1 cm. Staggering the lengths of the proximal segments 198 may axially elongate the zone in the left atrial appendage against which the proximal ends 204 provide anchoring support for the occlusion device.

35 The occlusion device 10 illustrated in Figures 26 and 27 is additionally provided with a hinge 206 to allow the longitudinal axis of the occlusion member 11 to be angularly oriented with respect to the longitudinal axis of the

5 stabilizing member 194. In the illustrated embodiment, the hinge 206 is a helical coil, although any of a variety of
hinge structures can be utilized. The illustrated embodiment may be conveniently formed by laser cutting a helical slot
through a section of the tube from which the principal structural components of the occlusion device 10 are formed.
10 At the distal end of the hinge 206, an annular band 208 connects the hinge 206 to a plurality of axially extending
5 struts 210. In the illustrated embodiment 210, three axial struts 210 are provided, spaced equilaterally around the
circumference of the body. Axial struts 210 may be formed from a portion of the wall of the original tube stock, which
portion is left in its original axial orientation following formation of the distal segments 198 such as by laser cutting
from the tubular wall.

15 The occlusion member 11 is provided with a proximal zone 212 on each of the spokes 17. Proximal zone 212
10 has an enhanced degree of flexibility, to accommodate the fit between the occlusion member 11 and the wall of the
left atrial appendage. Proximal section 212 may be formed by reducing the cross sectional area of each of the spokes
17, or by increasing the length of each spoke by making a wave pattern as illustrated.

20 Each of the spokes 17 terminates in a proximal point 214. Proximal point 214 may be contained within
layers of the barrier 15, or may extend through or beyond the barrier 15 such as to engage adjacent tissue and assist
15 in retaining the occlusion device 10 at the deployment site.

25 Referring to Figures 28 and 29, a further variation on the occlusion device 10 illustrated in Figures 24 and 25
is provided. The occlusion device 10 is provided with a proximal face 216 on the occlusion member 11, instead of the
open and proximally concave face on the embodiment of Figures 24 and 25. The proximal face 216 is formed by
30 providing a proximal spoke 218 which connects at an apex 220 to each distal spoke 17. Proximal spokes 218 are
20 each attached to a hub 222 at the proximal end 192 of the occlusion device 10. The barrier 15 may surround either
the proximal face or the distal face or both on the occlusion member 11. In general, provision of a proximal spoke 218
connected by an apex 220 to a distal spoke 17 provides a greater radial force than a distal spoke 17 alone, which will
35 provide an increased resistance to compression if the occlusion member 11 is positioned with the LAA.

40 Referring to Figures 30-35, an alternate embodiment of the occlusion device in accordance with the present
25 invention is illustrated. In general, the occlusion device 10 comprises an occluding member but does not include a
distinct stabilizing member as has been illustrated in connection with previous embodiments. Any of the embodiments
previously disclosed herein may also be constructed using the occluding member only, and omitting the stabilizing
member as will be apparent to those of skill in the art in view of the disclosure herein.

50 The occluding device 10 comprises a proximal end 192, a distal end 190, and a longitudinal axis extending
30 therebetween. A plurality of supports 228 extend between a proximal hub 222 and a distal hub 191. At least two or
three supports 228 are provided, and preferably at least about six. In one embodiment, eight supports 228 are
45 provided. However, the precise number of supports 228 can be modified, depending upon the desired physical
properties of the occlusion device 10 as will be apparent to those of skill in the art in view of the disclosure herein,
without departing from the present invention.

5 Each support 228 comprises a proximal spoke portion 218, a distal spoke portion 217, and an apex 220 as
has been discussed. However, each of the proximal spoke 218, distal spoke 17 and apex 220 may be a region on an
integral support 228, such as a continuous rib or frame member which extends in a generally curved configuration as
10 illustrated with a concavity facing towards the longitudinal axis of the occlusion device 10. Thus, no distinct point or
5 hinge at apex 220 is necessarily provided as is disclosed in previous embodiments, which include a hinged connection
between proximal spoke 218 and distal spoke 17.

15 At least some of the supports 228, and, preferably, each support 228, is provided with one or two or more
barbs 195. In the illustrated configuration, the occlusion device 10 is in its enlarged orientation, such as for occluding
a left atrial appendage or other body cavity or lumen. In this orientation, each of the barbs 195 projects generally
10 radially outwardly from the longitudinal axis, and are inclined in the proximal direction. In an embodiment where the
barbs 195 and corresponding support 228 are cut from a single ribbon, sheet or tube stock, the barb 195 will incline
20 radially outwardly at approximately a tangent to the curve formed by the support 228.

25 The occlusion device 10 illustrated in Figure 30 may be constructed in any of a variety of ways, as will
become apparent to those of skill in the art in view of the disclosure herein. In one preferred method, the occlusion
device 10 is constructed by laser cutting a piece of tube stock to provide a plurality of axially extending slots in-
between adjacent supports 228. Similarly, each barb 195 can be laser cut from the corresponding support 228 or
30 space in-between adjacent supports 228. The generally axially extending slots which separate adjacent supports 228
end a sufficient distance from each of the proximal end 192 and distal end 190 to leave a proximal hub 222 and a
distal hub 191 to which each of the supports 228 will attach. In this manner, an integral cage structure may be
20 formed. Alternatively, each of the components of the cage structure may be separately formed and attached together
such as through soldering, heat bonding, adhesives, and other fastening techniques which are known in the art. A
further method of manufacturing the occlusion device 10 is to laser cut a slot pattern on a flat sheet of appropriate
35 material, such as a flexible metal or polymer, as has been discussed in connection with previous embodiments. The
flat sheet may thereafter be rolled about an axis and opposing edges bonded together to form a tubular structure.

40 The apex portion 220 which carries the barb 195 may be advanced from a low profile orientation in which
each of the supports 228 extend generally parallel to the longitudinal axis, to an implanted orientation as illustrated, in
which the apex 220 and the barb 195 are positioned radially outwardly from the longitudinal axis. The support 228
may be biased towards the enlarged orientation, or may be advanced to the enlarged orientation following positioning
45 within the tubular anatomical structure, in any of a variety of manners. For example, referring to Figure 32, an
inflatable balloon 230 is positioned within the occlusion device 10. Inflatable balloon 230 is connected by way of a
removable coupling 232 to an inflation catheter 234. Inflation catheter 234 is provided with an inflation lumen for
providing communication between an inflation media source 236 outside of the patient and the balloon 230. Following
50 positioning within the target body lumen, the balloon 230 is inflated, thereby engaging barbs 195 with the surrounding
tissue. The inflation catheter 234 is thereafter removed, by decoupling the removable coupling 232, and the inflation
35 catheter 234 is thereafter removed.

5 In an alternate embodiment, the supports 228 are radially enlarged such as through the use of a deployment
catheter 238. Deployment catheter 238 comprises a lumen for movably receiving a deployment line 240. Deployment
line 240 extends in a loop 244 formed by a slip knot 242. As will be apparent from Figure 33, proximal retraction on
10 the deployment line 240 will cause the distal hub 191 to be drawn towards the proximal hub 222, thereby radially
enlarging the cross-sectional area of the occlusion device 10. Depending upon the material utilized for the occlusion
device 10, the supports 228 will retain the radially enlarged orientation by elastic deformation, or may be retained in
the enlarged orientation such as by securing the slip knot 242 immovably to the deployment line 240 at the fully
15 radially enlarged orientation. This may be accomplished in any of a variety of ways, using additional knots, clips,
adhesives, or other techniques known in the art.

10 Referring to Figures 34A and 34B, the occlusion device 10 may be provided with a barrier 15 such as a mesh
or fabric as has been previously discussed. Barrier 15 may be provided on only one hemisphere such as proximal face
216, or may be carried by the entire occlusion device 10 from proximal end 192 to distal end 190. The barrier may be
20 secured to the radially inwardly facing surface of the supports 228, as illustrated in Figure 34B, or may be provided on
the radially outwardly facing surfaces of supports 228, or both.

15 A further embodiment of the occlusion device 10 is illustrated in Figure 35, in which the apex 220 is
elongated in an axial direction to provide additional contact area between the occlusion device 10 and the wall of the
tubular structure. In this embodiment, one or two or three or more anchors 195 may be provided on each support 228,
depending upon the desired clinical performance. The occlusion device 10 illustrated in Figure 35 may also be provided
25 with any of a variety of other features discussed herein, such as a partial or complete barrier 15 covering. In addition,
the occlusion device 10 illustrated in Figure 35 may be enlarged using any of the techniques disclosed elsewhere
30 herein.

35 While particular forms of the invention have been described, it will be apparent that various modifications can
be made without departing from the spirit and scope of the invention. Accordingly, it is not intended that the invention
be limited, except as by the appended claims.

40

45

50

55

Claims

5

10

15

20

25

30

35

40

45

50

55

5

WHAT IS CLAIMED IS:

10

5

15

10

20

25

30

20

35

25

40

45

50

1. An occlusion device, for implantation within a tubular structure in the body comprising:
an occluding member, enlargeable from a reduced cross section to an enlarged cross section; and
a stabilizing member, enlargeable from a reduced cross section to an enlarged cross section.
2. An occlusion device as in Claim 1, wherein the enlarged cross section of the stabilizing member is less than the enlarged cross section of the occlusion member.
3. An occlusion device as in Claim 1, further comprising a hub between the occlusion member and the stabilizing member.
4. An occlusion device as in Claim 1, wherein the occlusion member comprises an expandable frame.
5. An occlusion device as in Claim 4, wherein the frame comprises at least two spokes.
6. An occlusion device as in Claim 5, wherein at least one spoke has a first end and a second end, and the first end is attached to the hub.
7. An occlusion device as in Claim 1, wherein the stabilizing member comprises at least two elements which are movable from an axial orientation when the stabilizing member is in the reduced cross section to an inclined orientation when the stabilizing element is in the enlarged cross section.
8. An occlusion device as in Claim 7, wherein each element comprises a proximal section, a distal section, and a bend in between the proximal and distal sections when the stabilizing member is in the enlarged cross section.
9. An occlusion device as in Claim 7, wherein the elements comprise wire.
10. An occlusion device as in Claim 7, wherein the elements are cut from a tube.
11. An occlusion device as in Claim 1, further comprising at least one tissue attachment element on the occluding member or the stabilizing member or both.
12. An occlusion device as in Claim 11, wherein the tissue attachment structure comprises a tissue piercing element.
13. A method of making an occlusion device, comprising the steps of:
providing a tube having a first end, a second end, and a longitudinal axis;
forming a plurality of axially extending slots at a first position on the tube to create a first plurality of longitudinal elements; and
forming a second plurality of axially extending slots at a second position on the tube to create a second plurality of longitudinal elements.
14. A method as in Claim 13, further comprising the step of providing a radially outwardly directed bias on at least one of the first and second plurality of elements.
15. A method as in Claim 13, further comprising the step of attaching a membrane or mesh to at least one of the first and second plurality of elements.

55

5

16. A method as in Claim 13, further comprising the step of providing a hinge on the tube in between the first and second plurality of elements.

10

5

17. A method as in Claim 16, wherein the providing a hinge step comprises providing a spiral cut in the tube.

18. A method as in Claim 13, wherein the forming step comprises cutting with a laser or etching.

15

10

19. An occlusion device, for occluding a hollow body structure, comprising:

a proximal end, a distal end, and a longitudinal axis extending therethrough;

at least three supports extending between the proximal end and the distal end;

each support comprising an elongate, flexible element which is movable from a first orientation in which the element extends substantially parallel to the axis at no more than a first distance from the axis, to a second orientation in which at least a portion of the element is inclined with respect to the axis and is separated by at least a second distance from the axis which is greater than the first distance.

20

20. An occlusion device as in Claim 19, comprising at least five supports.

25

15

21. An occlusion device as in Claim 19, further comprising a proximal hub at the proximal end and a distal hub at the distal end.

30

22. An occlusion device as in Claim 21, wherein the supports and the proximal hub and the distal hub are formed from a tube.

35

20

23. An occlusion device as in Claim 21, wherein the supports and the proximal hub and the distal hub are formed from a sheet.

24. An occlusion device as in Claim 19, further comprising at least one barb on each support.

40

25

25. An occlusion device as in Claim 20, further comprising at least one barb on each of at least two supports.

26. An occlusion device as in Claim 19, further comprising a barrier layer carried by the supports.

27. An occlusion device, for implantation with in a tubular structure in the body, comprising:

an occluding member comprising at least three spokes which are movable from a reduced cross-section to an enlarged cross-section, the spokes movable from an axial orientation when the occluding member is in the reduced cross-section to an inclined orientation when the occluding member is in the enlarged cross-section.

45

30

28. An occlusion device as in Claim 27, further comprising at least one hub on the occlusion member for holding the spokes.

50

29. An occlusion device as in Claim 27, wherein the occluding member comprises at least eight spokes.

30. An occlusion device as in Claim 28, wherein at least one spoke has a first end and a second end, and the first end is attached to the hub.

55

- 5 31. An occlusion device as in Claim 27, wherein each spoke comprises a proximal section, a distal section, and a bend in between the proximal and distal sections when the occluding member is in the enlarged cross-section.
- 10 32. An occlusion device as in Claim 27, wherein the spokes comprise wire.
- 5 33. An occlusion device as in Claim 27, wherein the spokes are cut from a tube.
34. An occlusion device as in Claim 27, further comprising at least one tissue attachment element on the occluding member.
- 15 35. An occlusion device as in Claim 34, wherein the tissue attachment structure comprises a tissue piercing element.
- 10 36. An occlusion device as in Claim 35, comprising at least one barb on each spoke.
- 20 37. An apparatus for preventing the passage of embolic material from a patient's left atrial appendage, comprising:
- (a) an occluding member having an outer periphery which is disposed around the occluding member and which is configured to engage the surface of a patient's left atrial appendage; and
- 15 (b) means for securing the outer periphery of the occluding member to the surface of the left atrial appendage.
- 25 38. The apparatus of claim 37 wherein the means for securing the outer periphery of the occluding member to the surface of a patient's left atrial appendage comprises an attachment means which is in contact with the outer periphery and at least a portion of the surface of the left atrial appendage.
- 30 39. The apparatus of claim 37 wherein the means for securing the outer periphery of the occluding member to the surface of a patient's left atrial appendage comprises a retention member secured to the occluding member.
- 35 40. An apparatus for preventing the passage of embolic material from a body cavity or passageway, comprising:
- 25 (a) an occluding member; and
- (b) a retention member secured to the occluding member and configured to engage an interior surface of the body cavity or passageway.
- 40 41. The apparatus of claim 40 wherein the retention member is an expandable member configured to engage an inside surface of the body cavity when in an expanded state.
- 30 42. The apparatus of claim 41 wherein the retention member is configured to engage the inside surface of a patient's left atrial appendage.
- 45 43. The apparatus of claim 42 wherein the expandable member is comprised of an expandable cylindrically shaped wire structure.
- 50 44. The apparatus of claim 43 wherein the expandable member is comprised of linked metallic elements capable of expansion from a constrained state.
- 55

- 5 45. The apparatus of claim 44 wherein the expandable member is self expanding from a constrained state.
46. The apparatus of claim 44 wherein the linked metallic elements are comprised of a pseudoelastic alloy.
- 10 5 47. The apparatus of claim 46 wherein the pseudoelastic alloy is NiTi.
48. The apparatus of claim 43 wherein the retention member further comprises an outer sheath disposed about and secured to the expandable member.
49. The apparatus of claim 48 wherein the outer sheath is comprised of a polymer mesh.
- 15 50. The apparatus of claim 48 wherein the outer sheath is comprised of PTFE.
51. The apparatus of claim 40 wherein the occluding member has a transverse dimension of about 1 to about 3 cm.
- 20 52. The apparatus of claim 40 wherein the retention member has a length of about 1 to about 5 cm.
53. The apparatus of claim 40 further comprising an outer periphery disposed about the occluding member configured to sealingly engage an interior surface of a patient's left atrial appendage.
54. The apparatus of claim 53 wherein the outer periphery has a substantially annular shape in a relaxed configuration.
- 25 55. The apparatus of claim 53 wherein the outer periphery is comprised of a soft polymer.
56. The apparatus of claim 40 wherein the occluding member is configured to engage the inside surface of a patient's left atrial appendage and the retention member comprises a shaft having at least one radially extending member extending radially therefrom and configured to engage the inside surface of the patient's left atrial appendage to limit axial movement of the occluding member secured thereto.
- 30 20 57. The apparatus of claim 56 wherein at least one of the radially extending members is comprised of NiTi pseudoelastic alloy.
58. The apparatus of claim 56 wherein the occluding member comprises a frame structure covered with a polymer mesh configured to prevent the passage of embolic material.
59. A device for occluding a body cavity of a patient comprising an occlusive body configured to at least partially fill the left atrial appendage of a patient.
- 40 60. The device of claim 59 wherein the occlusive body comprises an inflatable member.

45

50

55

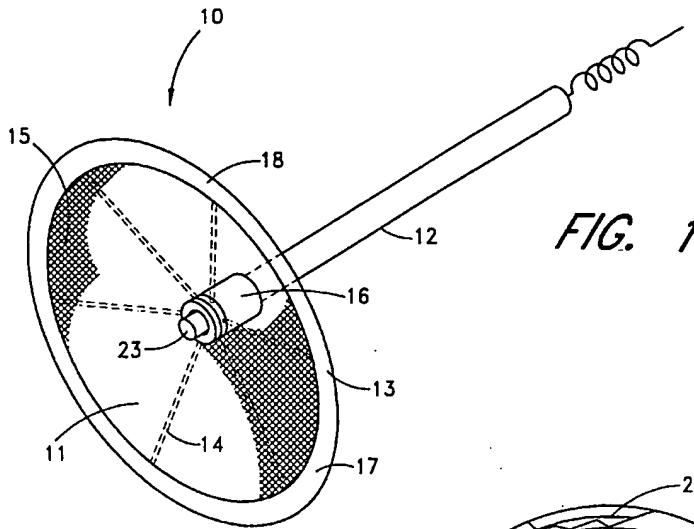

FIG. 1

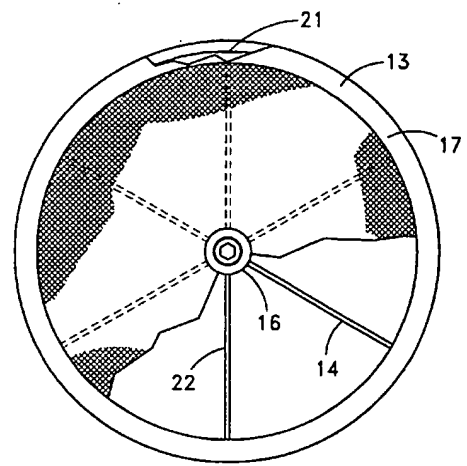

FIG. 2

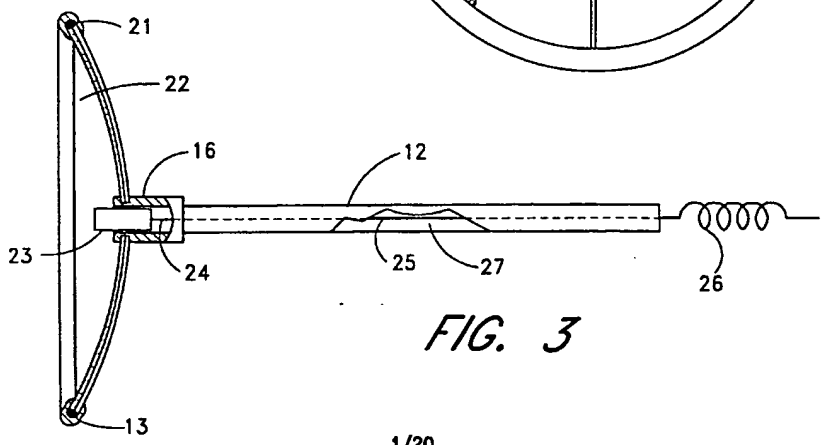
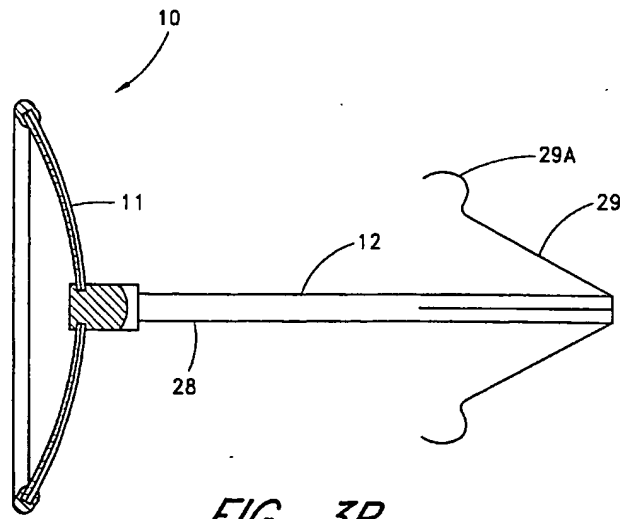
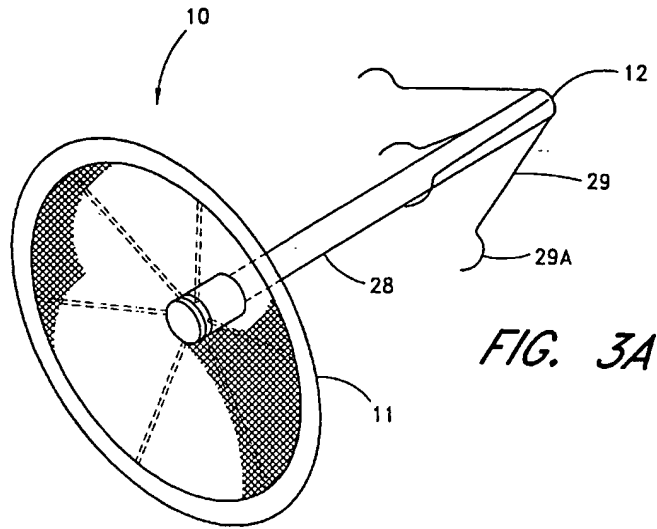
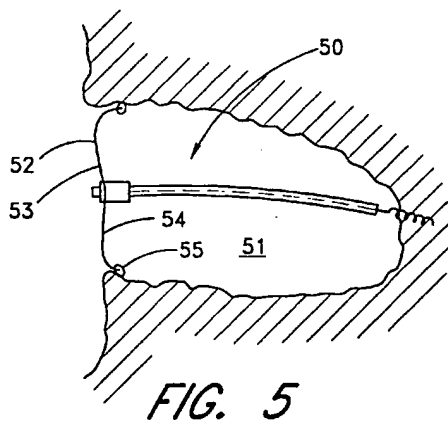
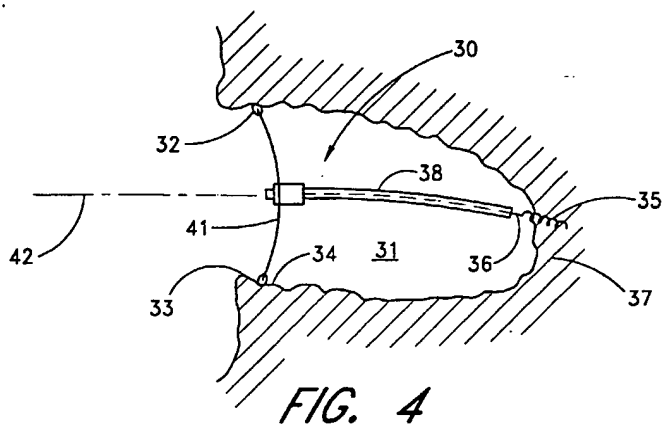

FIG. 3





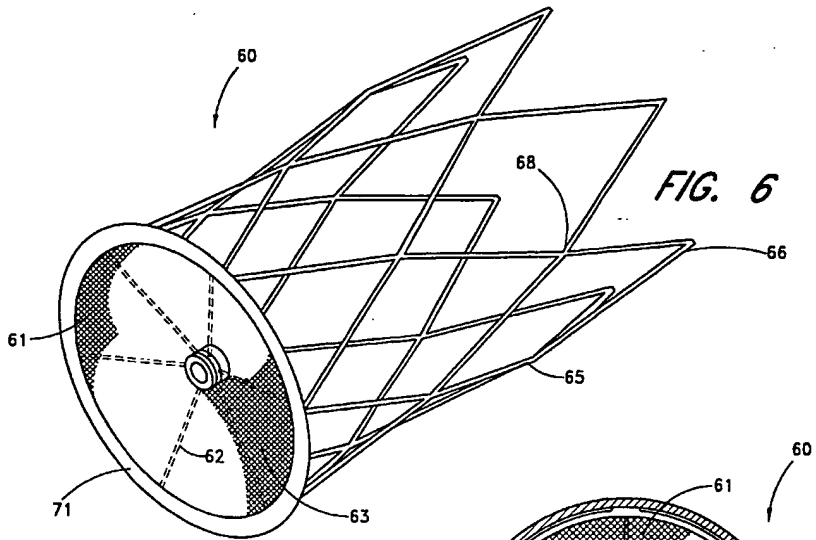
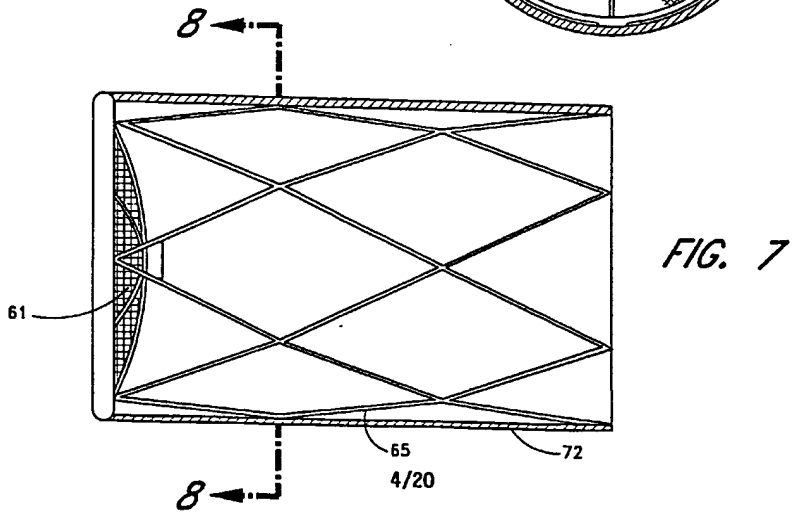
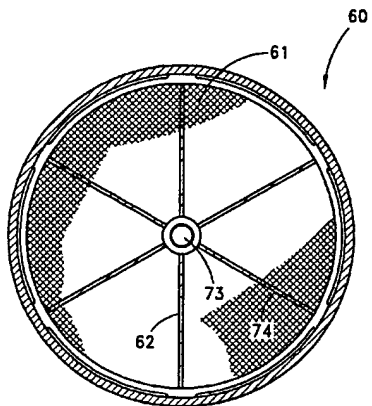
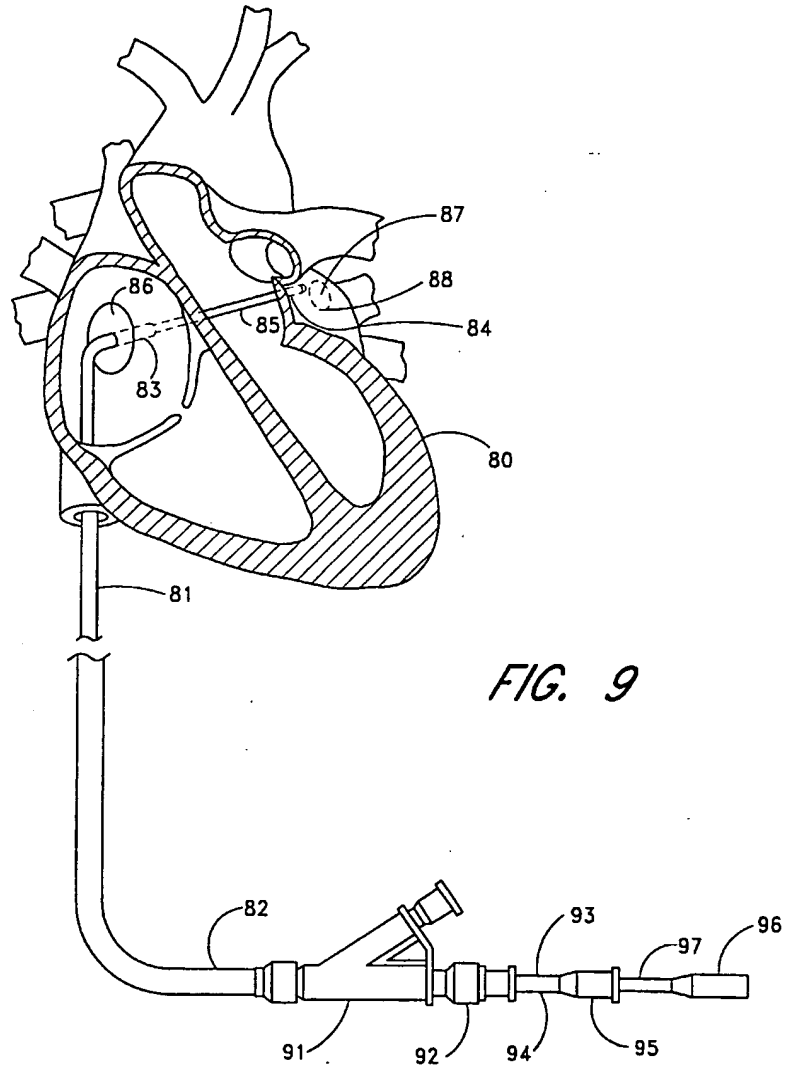

FIG. 8





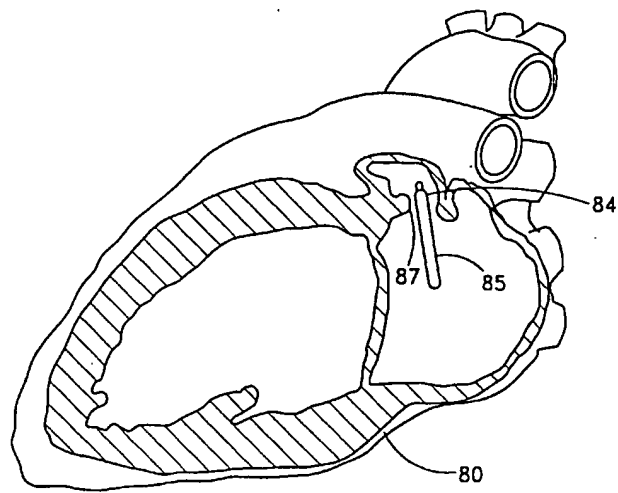

FIG. 10

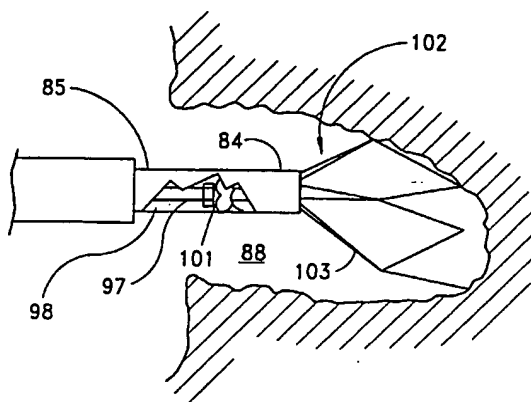

FIG. 11

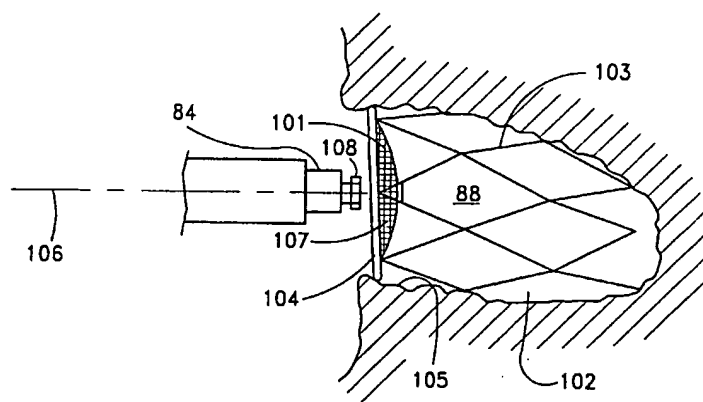

FIG. 12

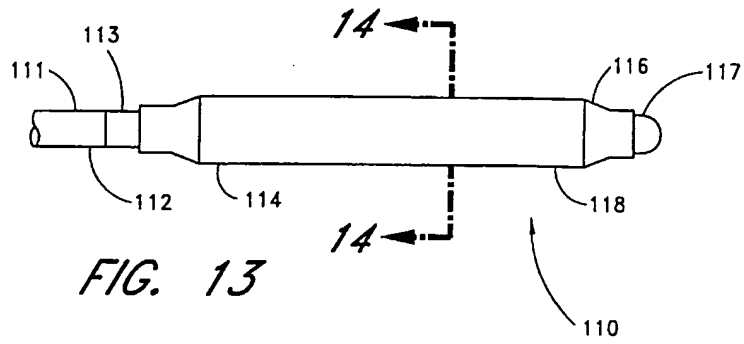

FIG. 13

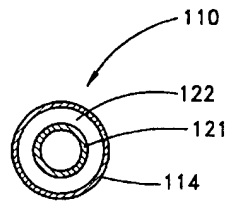
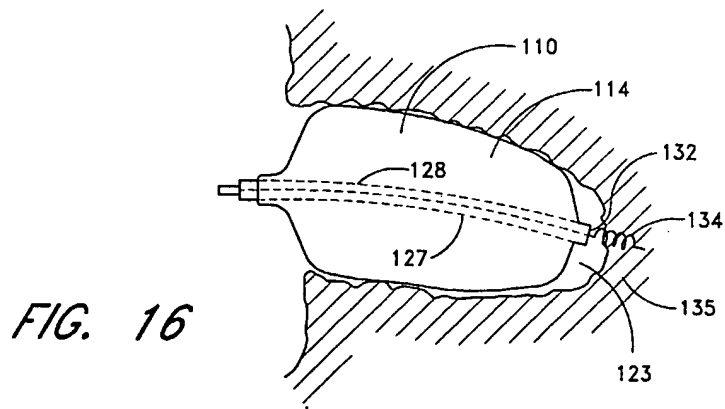
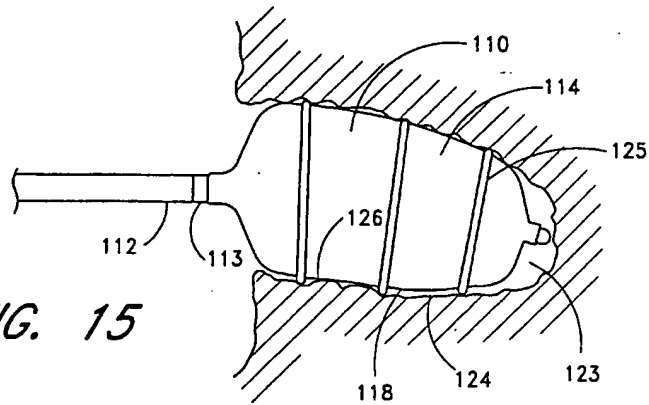
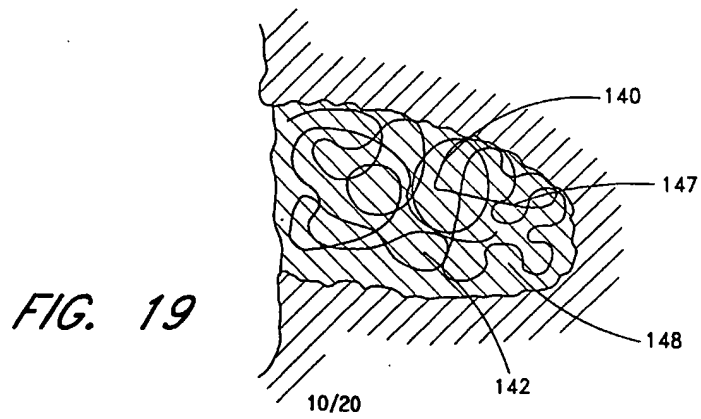
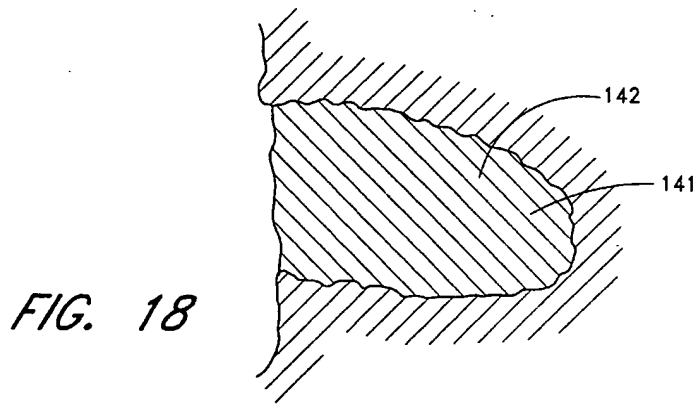
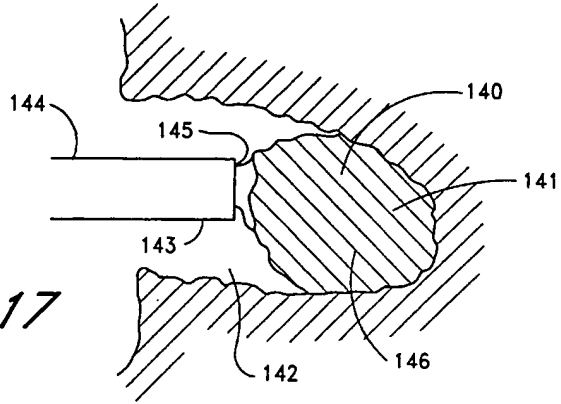

FIG. 14





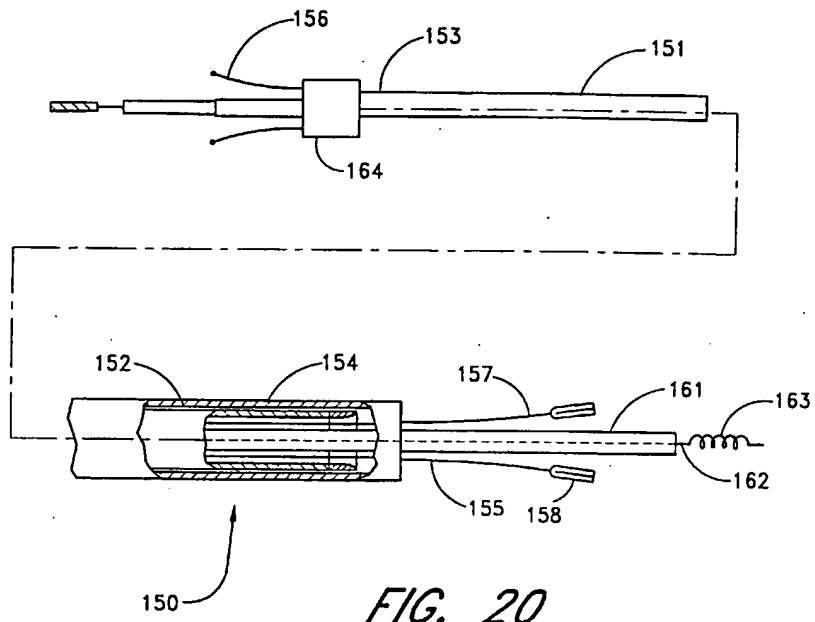
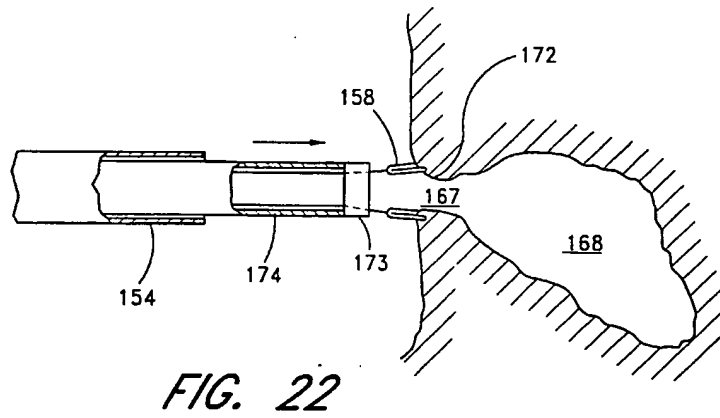
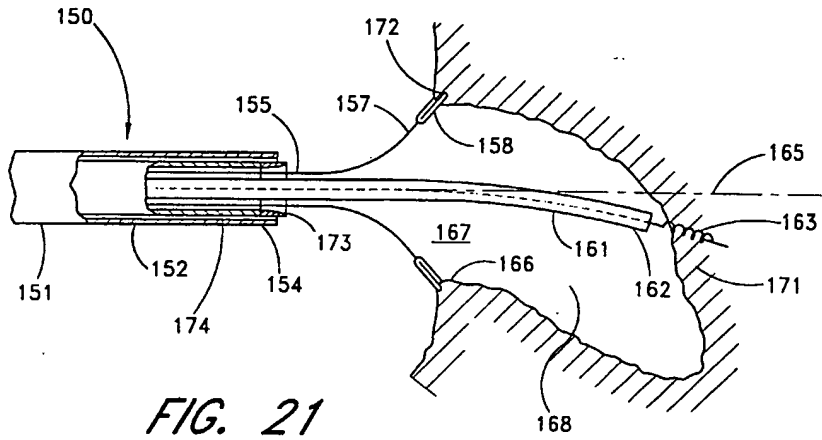

FIG. 20



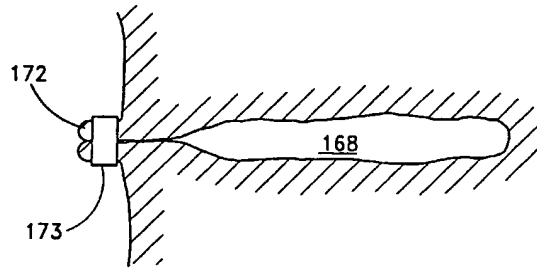

FIG. 23

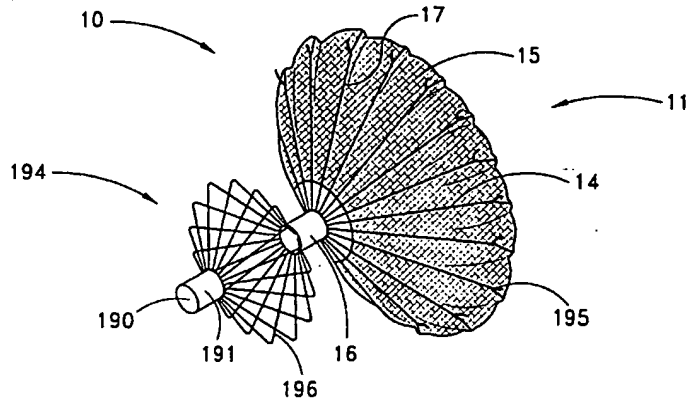

FIG. 24

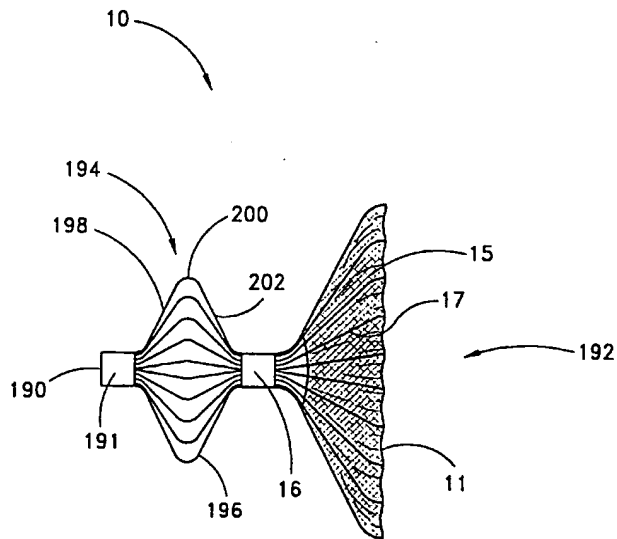

FIG. 25

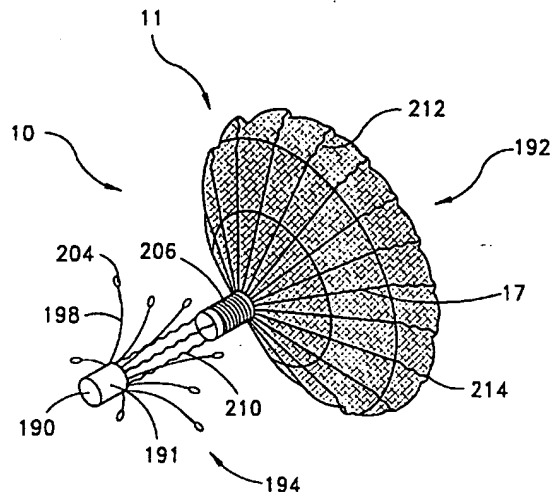

FIG. 26

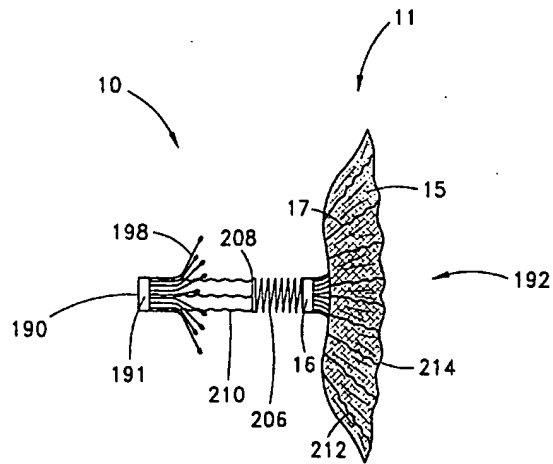

FIG. 27

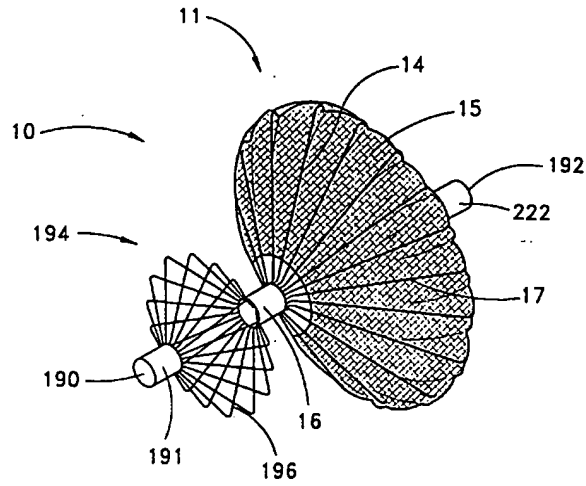

FIG. 28

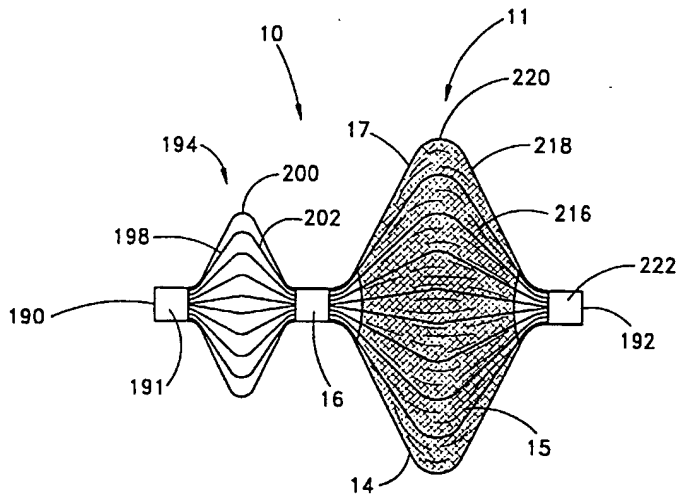

FIG. 29

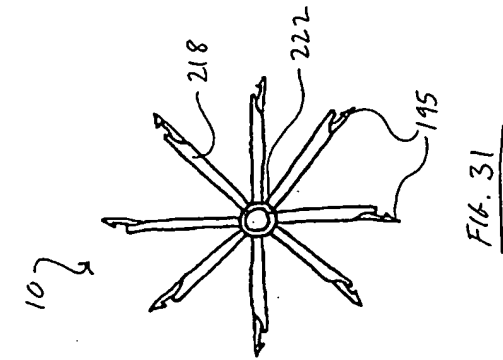

FIG. 31

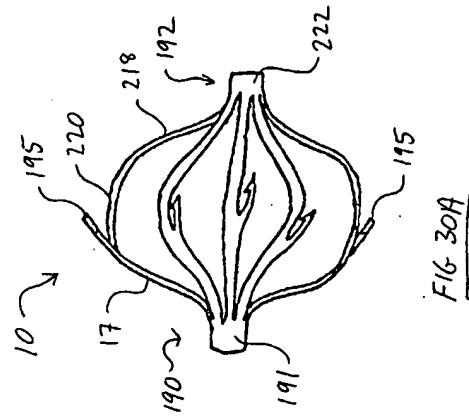

FIG. 30A

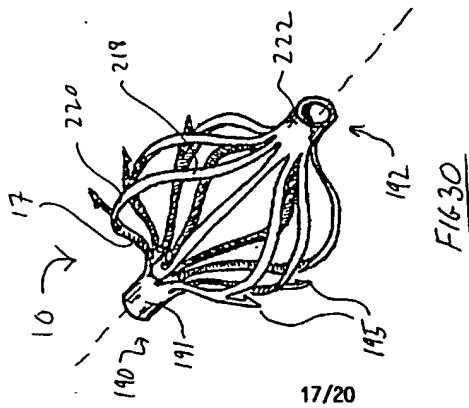
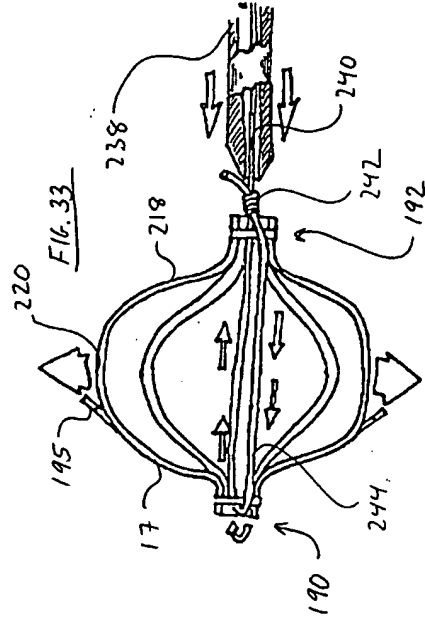
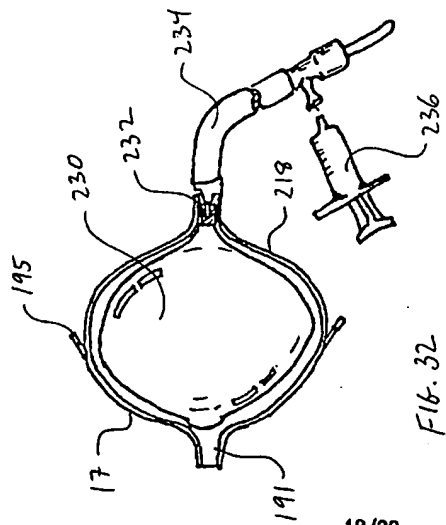

FIG. 30



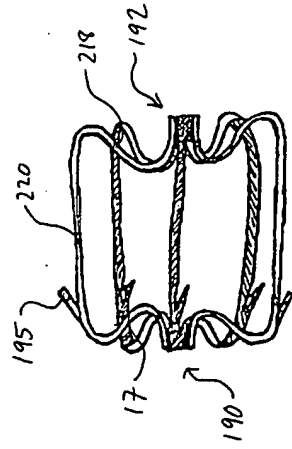

FIG. 35

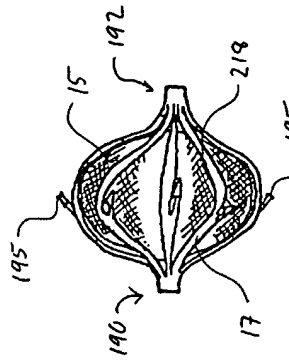

FIG. 34B

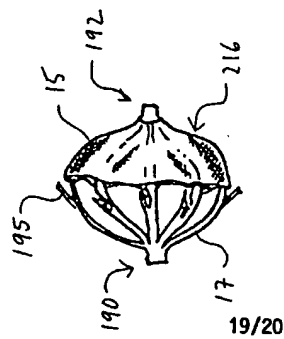
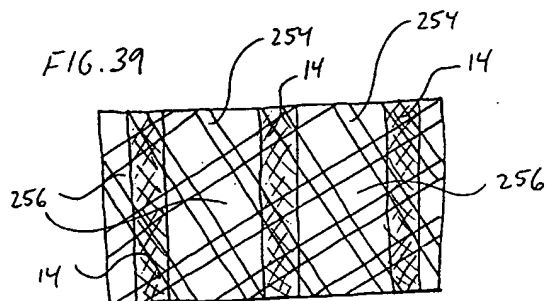
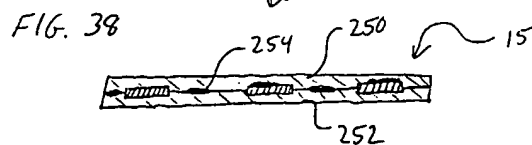
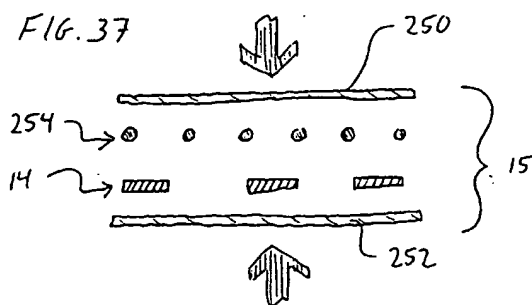
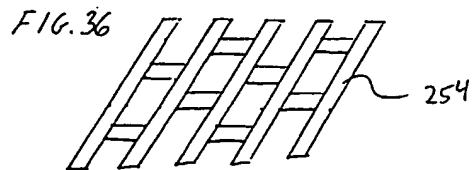
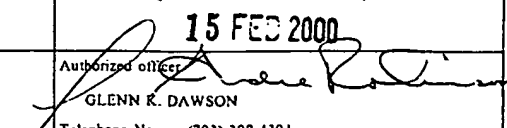

FIG. 34A



INTERNATIONAL SEARCH REPORT

International application No.
PCT/US99/26325

A. CLASSIFICATION OF SUBJECT MATTER IPC(6) :A61B 17/08 US CL :606/213 According to International Patent Classification (IPC) or to both national classification and IPC		
B. FIELDS SEARCHED Minimum documentation searched (classification system followed by classification symbols) U.S. : 606/1, 127, 151, 191-200, 213 Documentation searched other than minimum documentation to the extent that such documents are included in the fields searched Electronic data base consulted during the international search (name of data base and, where practicable, search terms used)		
C. DOCUMENTS CONSIDERED TO BE RELEVANT		
Category*	Citation of document, with indication, where appropriate, of the relevant passages	Relevant to claim No.
X	US 5,078,736 A (BEHL) 07 January 1992, entire document.	13
X	US 5,176,692 A (WILK et al.) 05 January 1993, entire document.	59, 60
X	US 5,464,408 A (DUC) 07 November 1995, col. 3 lines 46-56.	13, 14
Y		18
<input checked="" type="checkbox"/> Further documents are listed in the continuation of Box C. <input type="checkbox"/> See patent family annex.		
* Special categories of cited documents:		
"A"	document defining the general state of the art which is not considered to be of particular relevance	"T" late document published after the international filing date or priority date and not in conflict with the application but cited to understand the principle or theory underlying the invention
"E"	earlier document published on or after the international filing date	"X" document of particular relevance, the claimed invention cannot be considered novel or cannot be considered to involve an inventive step when the document is taken alone
"L"	document which may throw doubts on priority claims or which is cited to establish the publication date of another citation or other special reason (as specified)	"Y" document of particular relevance; the claimed invention cannot be considered to involve an inventive step when the document is combined with one or more other such documents, such combination being obvious to a person skilled in the art
"O"	document referring to an oral disclosure, use, exhibition or other means	"A" document member of the same patent family
"P"	document published prior to the international filing date but later than the priority date claimed	
Date of the actual completion of the international search	Date of mailing of the international search report	
21 JANUARY 2000	15 FEB 2000	
Name and mailing address of the ISA/US Commissioner of Patents and Trademarks Box PCT Washington, D.C. 20231 Facsimile No. (703) 305-3230	Authorized officer  GLENN R. DAWSON Telephone No. (703) 308-4304	

INTERNATIONAL SEARCH REPORT

International application No.
PCT/US99/26325

C (Continuation). DOCUMENTS CONSIDERED TO BE RELEVANT		
Category*	Citation of document, with indication, where appropriate, of the relevant passages	Relevant to claim No.
X ---P Y	US 5,836,968 A (SIMON et al.) 17 November 1998, entire document.	1-9, 11, 12, 19-21, 26-28, 30-32, 34, 35, 37-59 ----- 29
X,P	US 5,935,148 A (VILLAR et al.) 10 August 1999, entire document.	59